



KONICA MINOLTA

# PRECISE COLOR COMMUNICATION

COLOR CONTROL FROM PERCEPTION TO INSTRUMENTATION





**Knowing color.  
Knowing by color.  
In any environment,  
color attracts attention.**

An infinite number of colors surround us in our everyday lives. We all take color pretty much for granted, but it has a wide range of roles in our daily lives: not only does it influence our tastes in food and other purchases, the color of a person's face can also tell us about that person's health. Even though colors affect us so much and their importance continues to grow, our knowledge of color and its control is often insufficient, leading to a variety of problems in deciding product color or in business transactions involving color. Since judgement is often performed according to a person's impression or experience, it is impossible for everyone to visually control color accurately using common, uniform standards. Is there a way in which we can express a given color\* accurately, describe that color to another person, and have that person correctly reproduce the color we perceive? How can color communication between all fields of industry and study be performed smoothly? Clearly, we need more information and knowledge about color.

*\*In this booklet, color will be used as referring to the color of an object.*

# Contents

## PART I

---

|  |    |
|--|----|
| Why does an apple look red? .....  | 4  |
| Human beings can perceive specific wavelengths as colors. ....   | 6  |
| What color is this apple ? .....   | 8  |
| Two red balls. How would you describe the differences between their colors to someone? .....                             | 10 |
| Hue. Lightness. Saturation. The world of color is a mixture of these three attributes. ....                              | 12 |
| Hue, lightness, saturation. Let's create a color solid. ....   | 14 |
| By creating scales for hue, lightness, and saturation, we can measure color numerically. ....                            | 16 |
| Color meters make quantifying colors simple. ....  | 17 |
| Let's look at some color spaces. ....  | 18 |
| Color meters excel at reporting even minute color differences. ....  | 22 |
| Even if colors look the same to the human eye,<br>measurements with a color meter can point out slight differences. .... | 24 |

## PART II

---

|  |    |
|--|----|
| Differences in the color recognition process between the human eye and color meters..... | 28 |
| What about the components of light (and color)? Let's take a look. ....                  | 30 |
| Let's measure various colors with a color meter. ....                                    | 32 |
| Even though it's actually the same color, it looks different. Why? .....                 | 34 |
| Colors look different according to the light source. ....                                | 36 |
| A complex problem: Metamerism .....  | 38 |
| Colors also look different according to the subject conditions and environment. ....     | 40 |
| Colors also look different due to optical illusion and individual differences. ....      | 43 |
| Spectrophotometers solve these problems easily and quickly. ....                         | 44 |
| Measuring Special colors.....  | 45 |
| Notes for Measurement (Subjects and environment) .....                                   | 47 |

## PART III

---

|  |    |
|--|----|
| New Color Difference Formula (CIE 2000)..... | 49 |
|--|----|

## PART IV

---

|                   |    |
|-------------------|----|
| COLOR TERMS ..... | 53 |
|-------------------|----|

## **Let's study color.**

Even when we just look around, a wide variety of colors is readily visible. We are surrounded by an infinite variety of colors in our daily lives. However, unlike length or weight, there is no physical scale for measuring color, making it unlikely that everyone will express it in the same way when asked what a certain color is. For example, if we say "blue ocean" or "blue sky", each individual will imagine different blue colors, because their color sensitivity and past experiences are different. This is the difficulty with color.

We also do not understand the mechanism of commonplace phenomena concerning colors such as "Why do apples look red?".

This section describes important and useful information about colors.

# Why does an apple look red?



## **No light, no color. The three elements of light, vision, and object are necessary for us to perceive object color.**

In total darkness, we cannot know color. If we close our eyes, we cannot see the color of an object. And if there is no object, color does not exist. Light, vision, and object: if all three are not present, we cannot perceive color. But how can we tell the difference between colors, between the red of an apple and the yellow of a lemon?

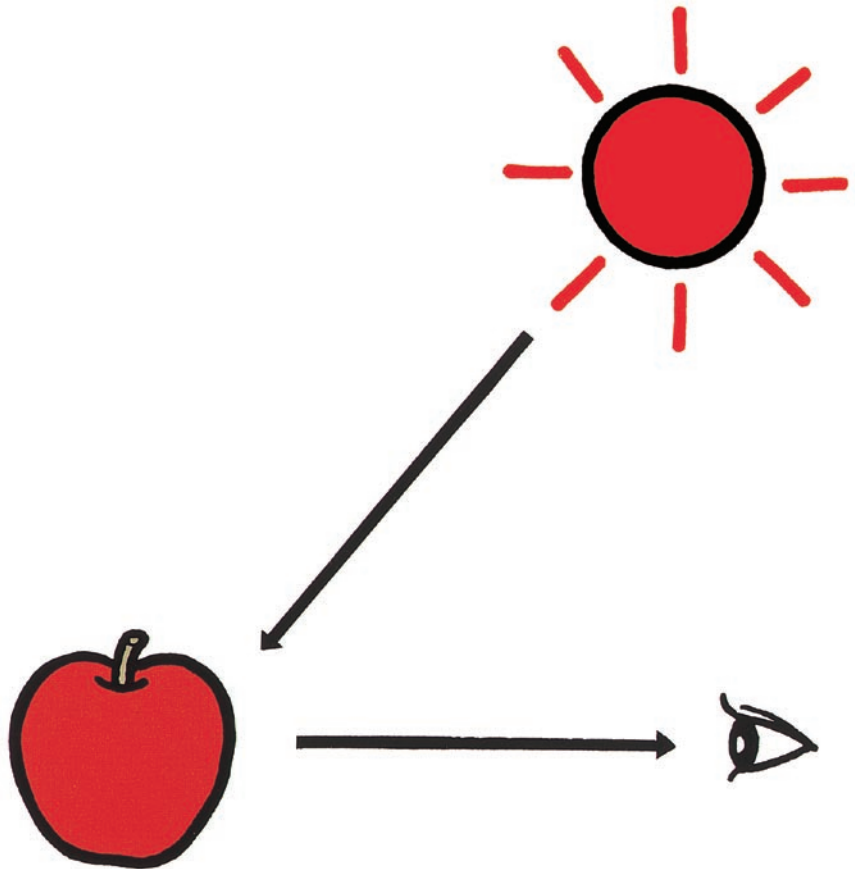

# Human beings can perceive specific wavelengths as colors.

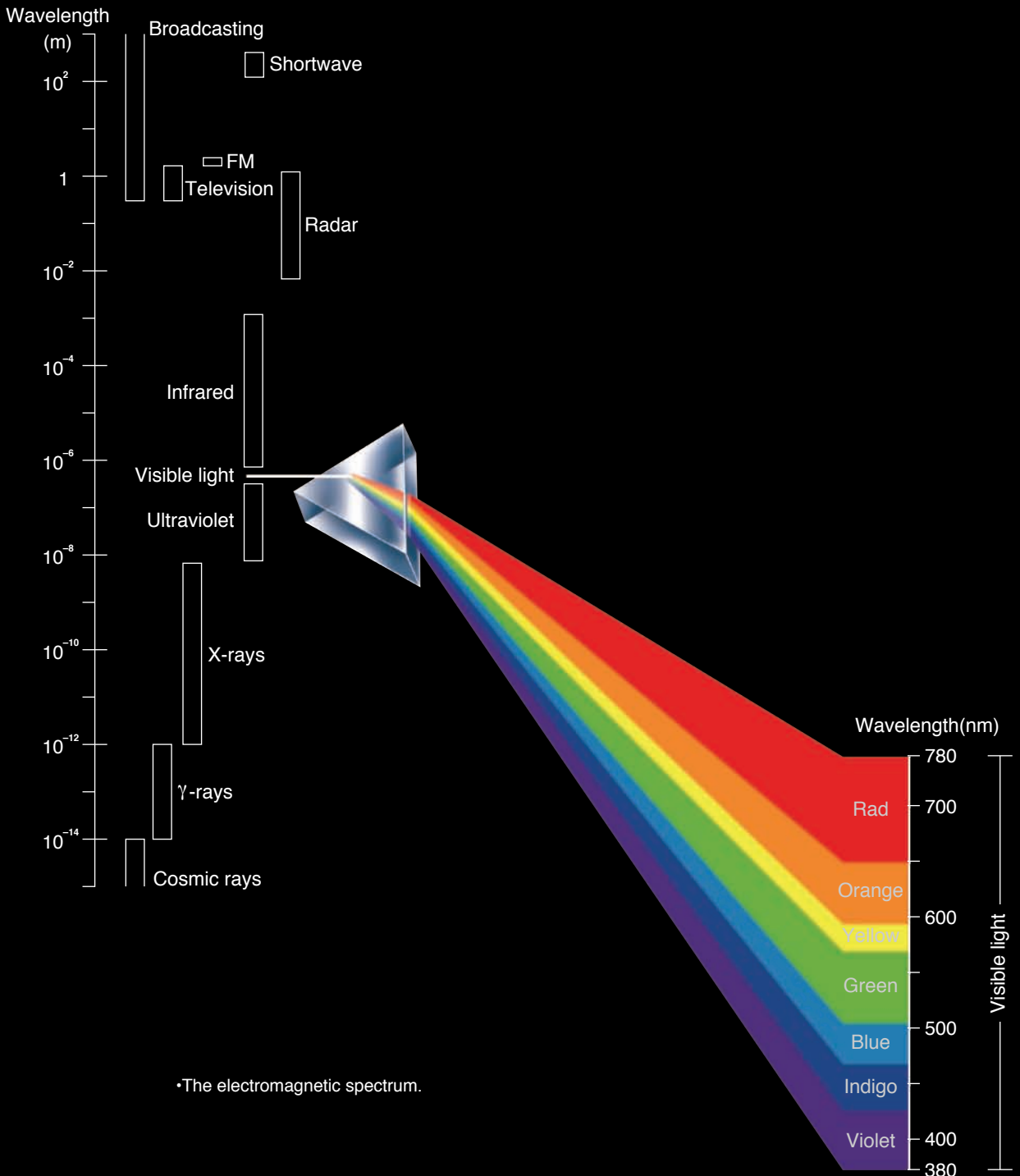

•The electromagnetic spectrum.

# If we separate light into its different wavelengths, we create a spectrum. We can then create the different colors by mixing the separated wavelengths of light in varying intensities.

Most people know that if we pass light from the sun through a prism, we create a color distribution like a rainbow. This phenomenon was discovered by Isaac Newton, who also discovered universal gravity. This distribution of colors is called a spectrum; separating light into a spectrum is called spectral dispersion. The reason that the human eye can see the spectrum is because those specific wavelengths stimulate the retina in the human eye. The spectrum is arranged in the order red, orange, yellow, green, blue, indigo, and violet according to the different wavelengths\*<sup>1</sup> of light; the light in the region with the longest wavelengths is seen as red, and the light in the region with the shortest wavelengths is seen as violet. The light region which the human eye can see is called the visible light region. If we move beyond the visible light region toward longer wavelengths, we enter the infrared region; if we move toward shorter wavelengths, we enter the ultraviolet region. Both of these regions cannot be seen by the human eye.

Light is just one portion of the various electromagnetic waves flying through space. The electromagnetic spectrum covers an extremely broad range, from electrical and radio waves with wavelengths of several thousand kilometers to gamma ( $\gamma$ ) rays with wavelengths of  $10^{-3}\text{nm}$  and shorter. The visible light region is only a very small portion of this: from approximately 380 to  $780\text{nm}$ \*<sup>2</sup>. The light reflected from an object and which we recognize as color is (with the exception of man-made monochromatic light) a mixture of light at various wavelengths within the visible region.

\*<sup>1</sup> Wavelength: Light has wave characteristics; wavelength is the peak-to-peak distance of two adjacent waves.

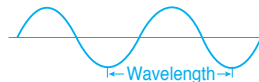

\*<sup>2</sup> nm(nanometer): A unit of measure often used when discussing wavelengths of light;  $\mu\text{m}$ (micrometer) is also sometimes used.

$$1\text{nm}=10^{-9}\text{m}=10^{-6}\text{mm}=10^{-3}\mu\text{m}$$
$$1\mu\text{m}=10^{-6}\text{m}=10^{-3}\text{mm}=10^3\text{nm}$$



- A rainbow is created by sunlight passing through fine water droplets in the air, which act as prisms.



What color is this apple ?



Red!

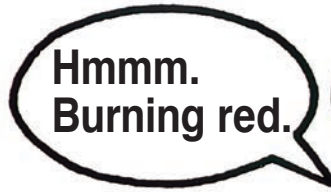

Hmmm.  
Burning red.

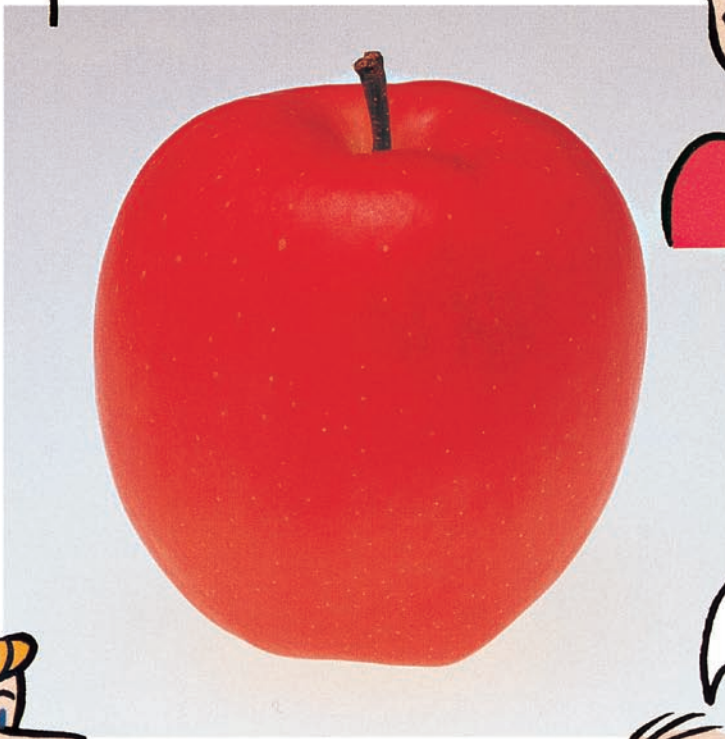

I'd say  
crimson.

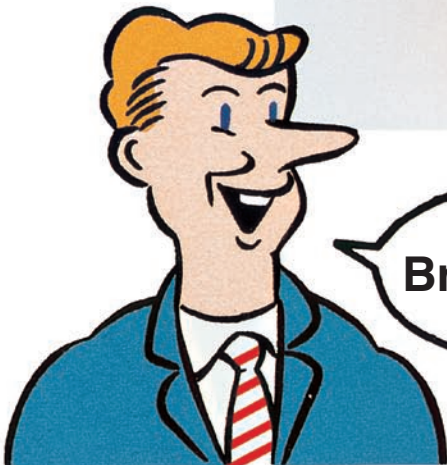

Bright Red.



**A color expression often means ten different colors to ten different people.**

**“Name this color” is a very difficult thing to do.**

**If you show the same apple to four different people, you are bound to get four different answers.**

Color is a matter of perception and subjective interpretation. Even if they are looking at the same object (in this case, an apple), people will draw upon different references and experiences and express the exact same color in vastly different words. Because there is such a wide variety of ways to express a color, describing a particular color to someone is extremely difficult and vague. If we describe the color of the apple to someone as “burning red”, can we expect them to be able to reproduce that color exactly? Verbal expression of color is too complicated and difficult. However, if there was a standard method by which colors could be accurately expressed and understood by anyone, color communication would be much smoother, simpler, and exact. Such precise color communication would eliminate color-related problems.

**To what extent can words express color?**

**Common color names and systematic color names.**

Words for expressing colors have always changed with the times. If we consider, for instance, the red we’ve been talking about, there are “vermillion”, “cinnabar”, “crimson”, “rose”, “strawberry”, and “scarlet”, to mention just a few. These are called common color names. By analyzing the color condition and adding adjectives such as “bright”, “dull”, and “deep”, we can describe the color a little more precisely. Terms such as the “bright red” used by the man on the facing page are called systematic color names. Although there are a variety of such ways to describe color, different people hearing just “crimson” or “bright red” will still interpret such expressions in different ways. So verbal expression of colors is still not accurate enough. Then how should colors be expressed to avoid the possibility of misunderstanding?



**Two red balls.**

**How would you describe the differences between their colors to someone?**

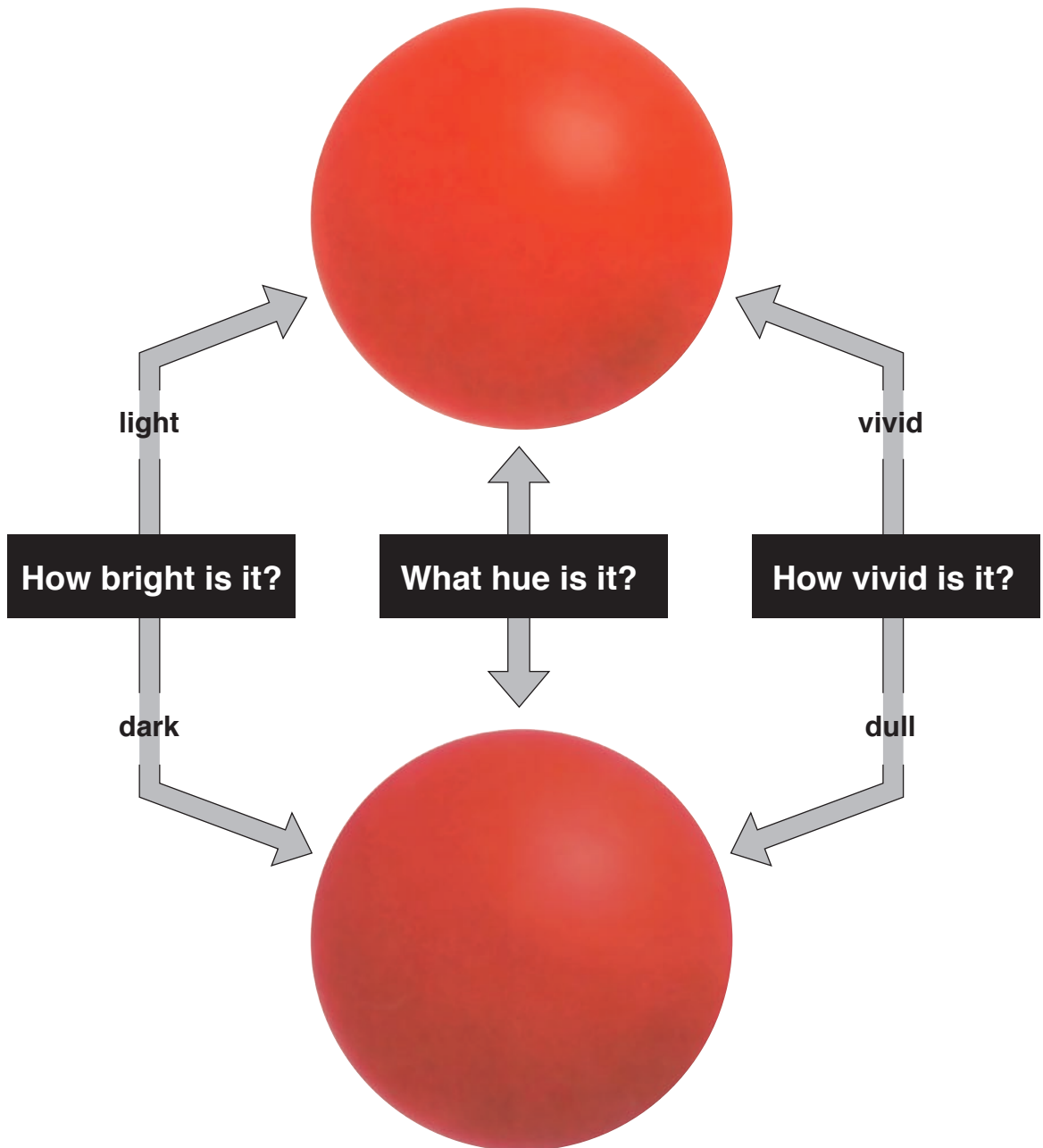

## **To better understand accurate color expression, let's take a look at the world of color.**

**There are many different “red” colors. The reds of the two balls at left are very similar. How are they different?**

Two red balls are shown at left. At first glance they look the same, but upon closer examination you realize they are different in several ways. The color of both is red, but the color of the upper ball is somewhat brighter and the color of the lower ball is thus darker. Also, the color of the upper ball appears vivid. So you can see that even though they both appear red, the colors of the two balls are different. When colors are classified, they can be expressed in terms of their hue (color), lightness (brightness), and saturation (vividness).

# Hue. Lightness. Saturation. The world of color is a mixture of these three attributes.

Figure 1: Color wheel

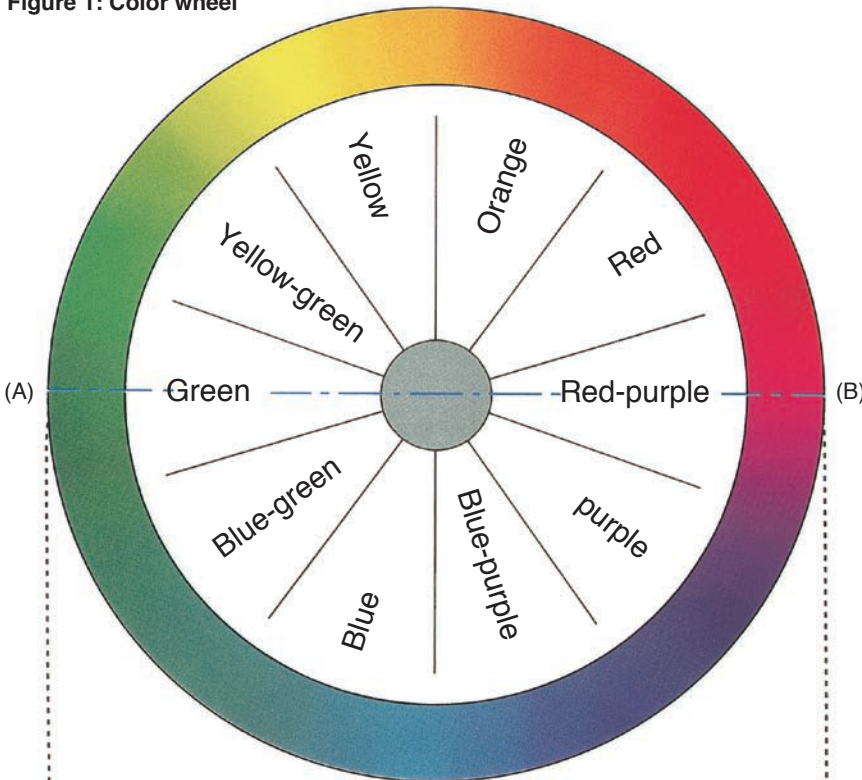

Figure 2: Changes in lightness and saturation for red-purple and green

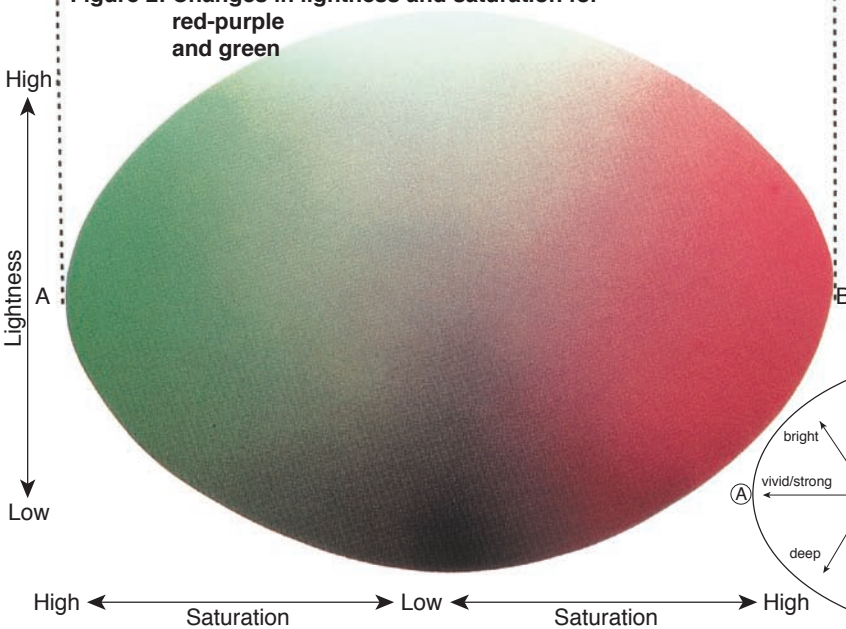
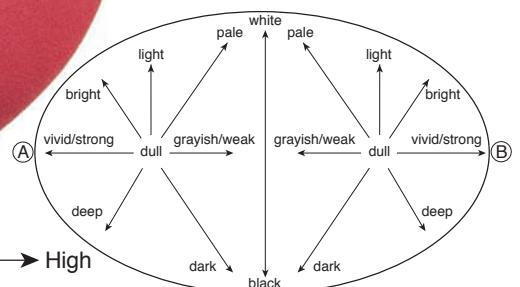

Figure 3: Adjectives related to colors



## **Hue, lightness, and saturation: This is the world of color.**

### **Hue** Red, yellow, green, blue... Hues form the color wheel.

Apples are red, lemons are yellow, the sky is blue; that's how we all think of color in everyday language. Hue is the term used in the world of color for the classifications of red, yellow, blue, etc. Also, although yellow and red are two completely different hues, mixing yellow and red together results in orange (which is sometimes referred to as yellow-red), mixing yellow and green results in yellow-green, mixing blue and green results in blue-green, and so on. The continuum of these hues results in the color wheel shown in Figure 1.

### **Lightness** Bright colors, dark colors. The lightness of colors changes vertically.

Colors can be separated into bright and dark colors when their lightnesses (how bright they are) are compared. Take, for example, the yellows of a lemon and a grapefruit. Without a doubt, the yellow of the lemon is much brighter. How about the yellow of a lemon and the red of a sweet cherry. Again, the yellow of the lemon is brighter, right? This lightness can be measured independently of hue. Now take a look at Figure 2. This figure is a cross section of Figure 1, cut along a straight line between A (Green) and B (Redpurple). As the figure shows, lightness increases toward the top and decreases toward the bottom.

### **Saturation** Vivid colors, dull colors. Saturation changes outward from the center.

Going back to yellow, how do you compare the yellows of a lemon and a pear? You might say the yellow of the lemon is brighter, but more to the point in this case, it is vivid, while the yellow of the pear is dull. This is another big difference, but this time one of color saturation or vividness. This attribute is completely separate from those of both hue and lightness. If we look at Figure 2 again, we can see that saturation changes for red-purple and green respectively as the horizontal distance from the center changes. Colors are dull near the center and become more vivid as we move away from the center. Figure 3 shows general adjectives used to describe the lightness and saturation of colors. To see what the words express, look back at Figure 2 again.

# Hue, lightness, saturation.

## Let's create a color solid.

If we use the change of lightness as the axis of the color wheel and the change of saturation as the spokes...

Hue, lightness, and saturation. These three elements are the three color attributes, and can be put together to create the three dimensional solid shown in Figure 4. Hues form the outer rim of the solid, with lightness as the center axis and saturation as the horizontal spokes. If the actual colors which exist in the world were distributed around the solid shown in Figure 4, the color solid shown in Figure 5 would be created. The shape of the color solid is somewhat complicated because the size of the steps for saturation are different for each hue and lightness, but the color solid helps us to better visualize the relationship between hue, lightness, and saturation.

Figure 4:  
Three-dimensional  
(hue, lightness, saturation) solid

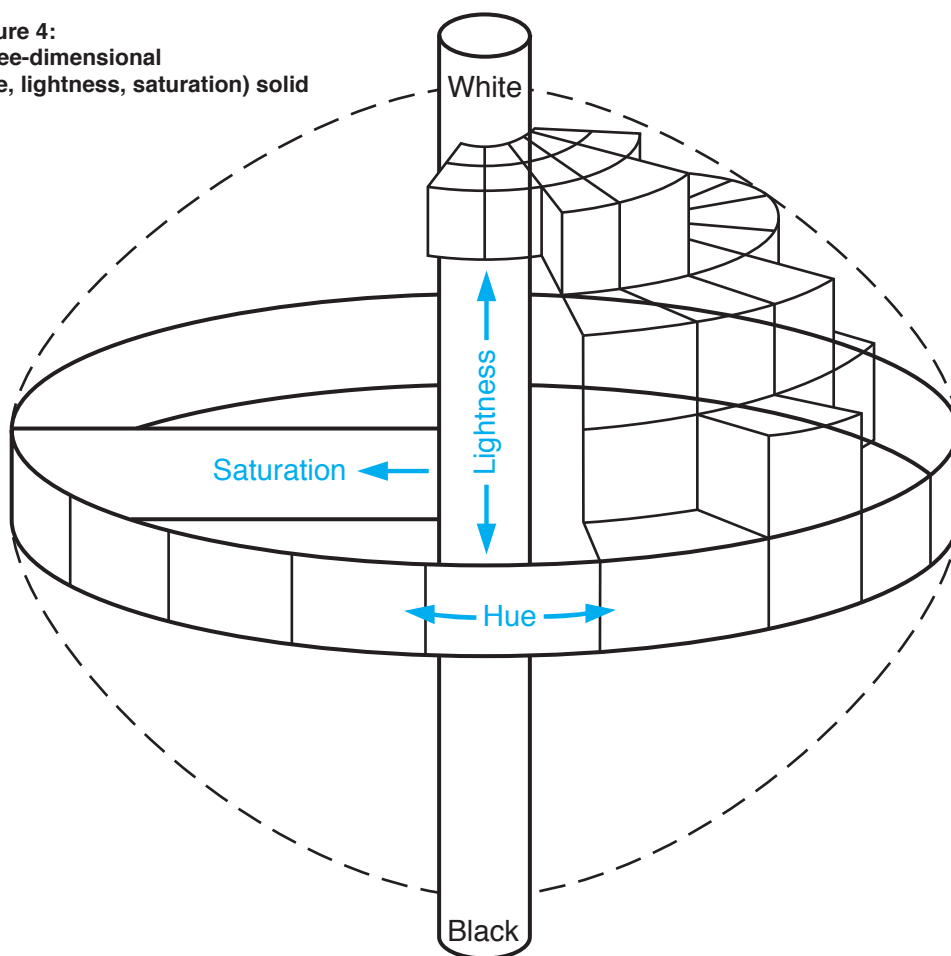
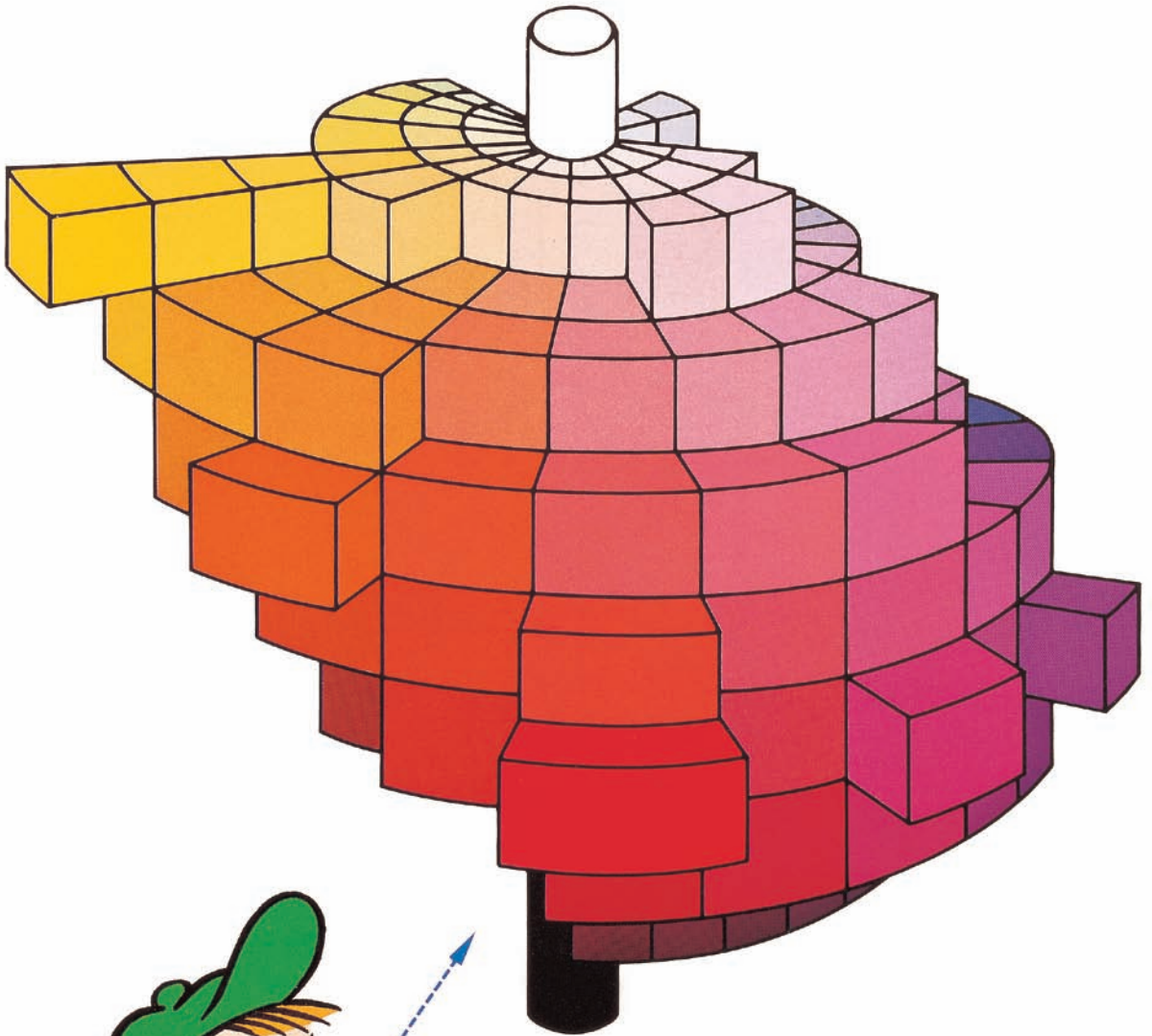

Figure 5: Color solid



If we look for the color of the apple on the color solid, we can see that its hue, lightness, and saturation intersect in the red area.



# By creating scales for hue, lightness, and saturation, we can measure color numerically.

## History of expressing colors numerically

Everyone would find it useful to be able to communicate about color more easily and accurately. In the history of color, many people have tried to devise their own methods for expressing color quantitatively. These methods provided a way of expressing colors numerically, in much the same way that we express length or weight. For example, in 1905 the American artist A. H. Munsell devised a method for expressing colors by using a great number of paper color chips of different hue (Munsell Hue), lightness (Munsell Value), and saturation (Munsell Chroma) for visual comparison with a specimen color. This method was the basis of the Munsell Renotation System, which is the Munsell Color System presently in use. In this system, any given color is expressed as a letter/number combination (H V/C) in terms of its hue (H), value (V), and chroma (C) as visually evaluated using the Munsell Color Charts.

Other methods for expressing color numerically were developed by an international organization concerned with light and color, the Commission Internationale de l'Eclairage (CIE). The two most widely known of these methods are the Yxy color space, devised in 1931 based on the tristimulus values XYZ defined by CIE, and the  $L^*a^*b^*$  color space, devised in 1976 to provide more uniform color differences in relation to visual differences. After various improvements, color spaces\* such as these are now used throughout the world for color communication.

*\*Color space: Method for expressing the color of an object or a light source using some kind of notation, such as numbers.*



## Color meters make quantifying colors simple.

By using a color meter, we can obtain results instantly for each color space.

If we measure the color of the apple, we get the following results:



### L\*a\*b\* color space

L\* = 43.31  
a\* = 47.63  
b\* = 14.12

### L\*C\*h\* color space

L\* = 43.31  
C\* = 49.68  
h = 16.5

### XYZ (Yxy) color space

Y = 13.37  
x = 0.4832  
y = 0.3045

# Let's look at some color spaces.

## L\*a\*b\* color space

The L\*a\*b\* color space (also referred to as CIELAB) is presently one of the most popular color spaces for measuring object color and is widely used in virtually all fields. It is one of the uniform color spaces defined by CIE in 1976 in order to reduce one of the major problems of the original Yxy color space: that equal distances on the x, y chromaticity diagram did not correspond to equal perceived color differences. In this color space, L\* indicates lightness and a\* and b\* are the chromaticity coordinates. Figure 6 shows the a\*, b\* chromaticity diagram. In this diagram, the a\* and b\* indicate color directions: +a\* is the red direction, -a\* is the green direction, +b\* is the yellow direction, and -b\* is the blue direction. The center is achromatic; as the a\* and b\* values increase and the point moves out from the center, the saturation of the color increases. Figure 8 is a representation of the color solid for the L\*a\*b\* color space; Figure 6 is a view of this solid cut horizontally at a constant L\* value.

If we measure the apple using the L\*a\*b\* color space, we obtain the following values.



L\* = 43.31  
a\* = 47.63  
b\* = 14.12

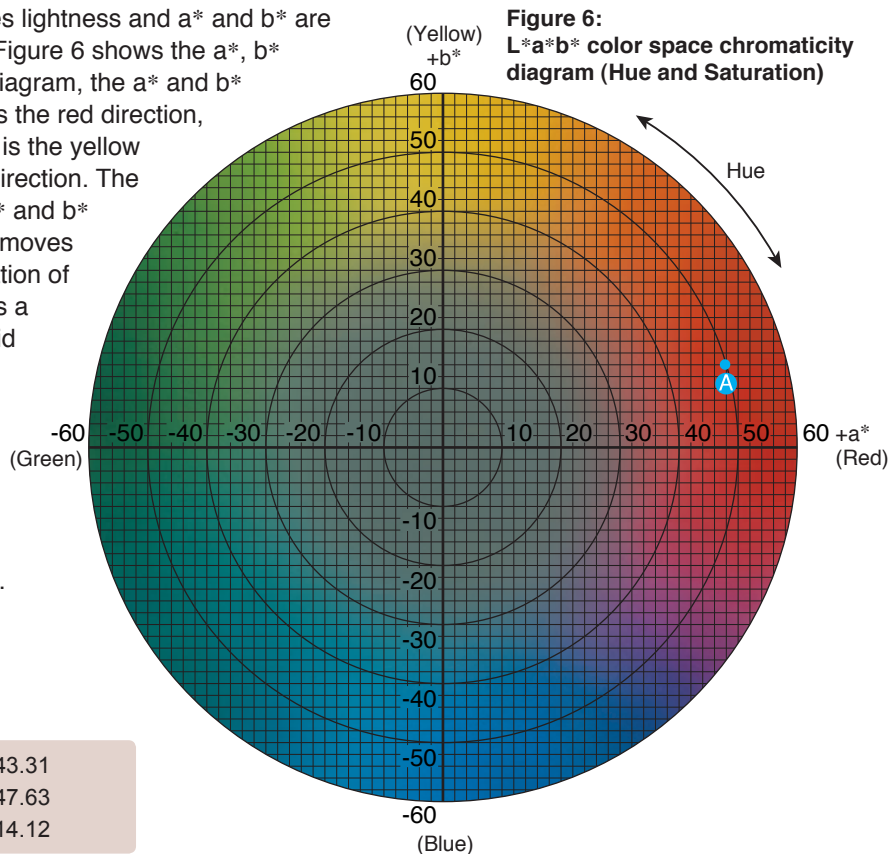

Figure 6:  
L\*a\*b\* color space chromaticity diagram (Hue and Saturation)

To see what color these values represent, let's first plot the a\* and b\* values (a\* = +47.63, b\* = +14.12) on the L\*a\*b\* diagram in Figure 6 to obtain point A, which shows the chromaticity of the apple. Now, if we cut the solid color of Figure 6 vertically through point A and the center, we obtain a view of lightness versus saturation\*, part of which is shown in Figure 7. On this diagram, point B, which is the lightness of the apple, can be determined (L\* = 43.31). The color of this apple can be expressed like this: A vivid color with red hue.

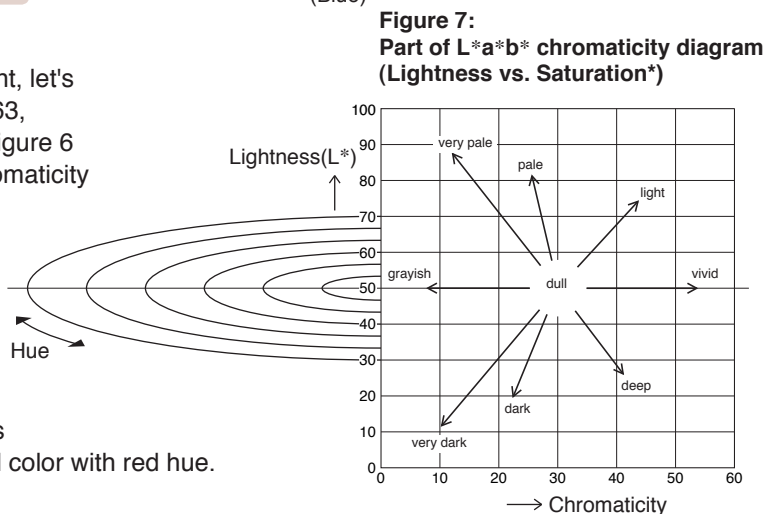
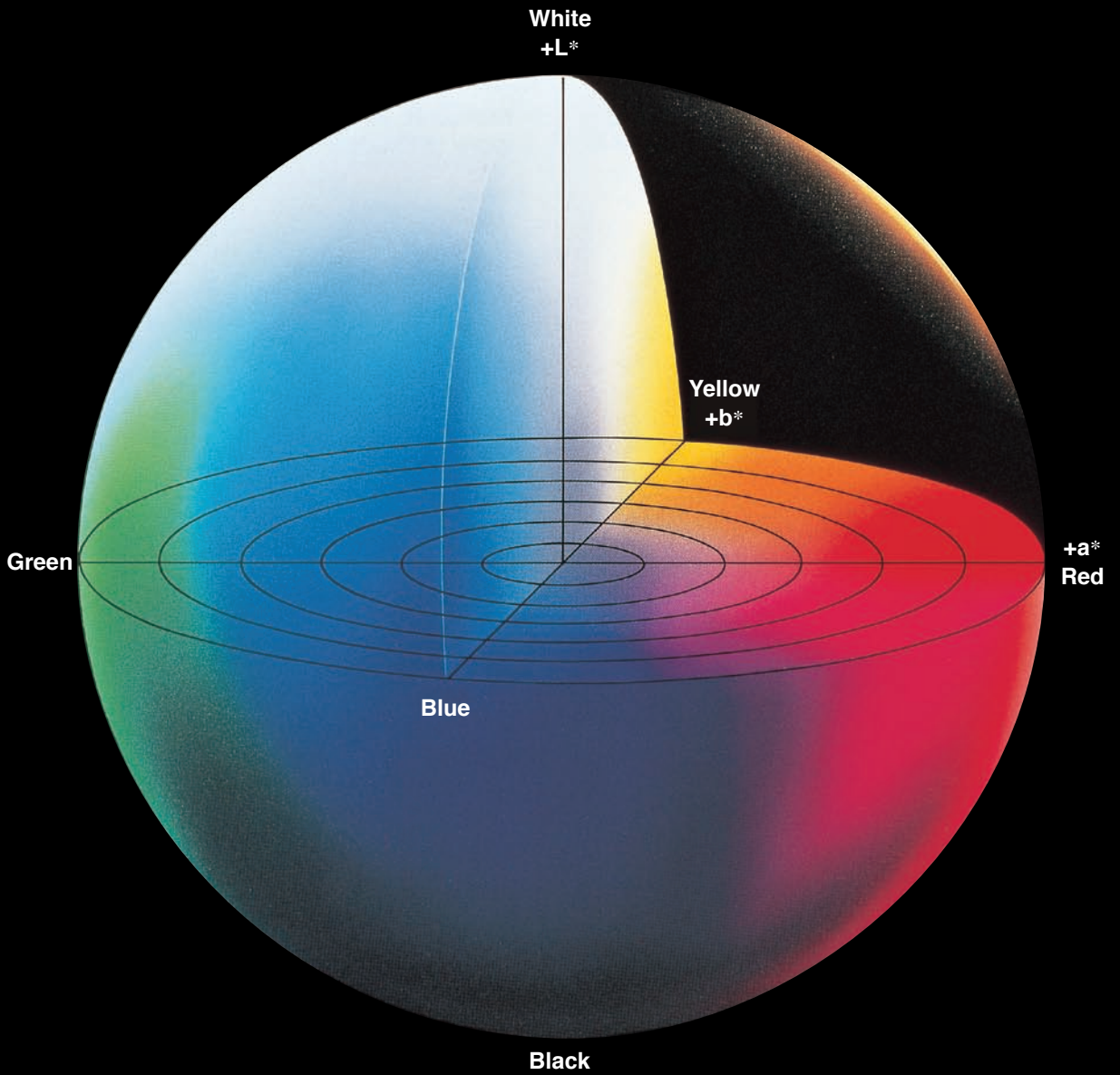

Figure 7:  
Part of L\*a\*b\* chromaticity diagram (Lightness vs. Saturation\*)

Figure 8: Representation of color solid for L\*a\*b\* color space



# L\*C\*h color space

The L\*C\*h color space uses the same diagram as the L\*a\*b\* color space, but uses cylindrical coordinates instead of rectangular coordinates. In this color space, L\* indicates lightness and is the same as the L\* of the L\*a\*b\* color space, C\* is chroma, and h is the hue angle. The value of chroma C\* is 0 at the center and increases according to the distance from the center. Hue angle h is defined as starting at the +a\* axis and is expressed in degrees; 0° would be +a\* (red), 90° would be +b\* (yellow), 180° would be -a\* (green), and 270° would be -b\* (blue). If we measure the apple using the L\*C\*h color space, we get the results shown below. If we plot these values on Figure 9, we obtain point A.



L\* = 43.31  
 C\* = 49.68  
 h = 16.5

Chroma  $C^* = \sqrt{(a^*)^2 + (b^*)^2}$

Hue angle  $h_{ab} = \tan^{-1}\left(\frac{b^*}{a^*}\right)$

Figure 9: Portion of a\*, b\* chromaticity diagram of Figure 6

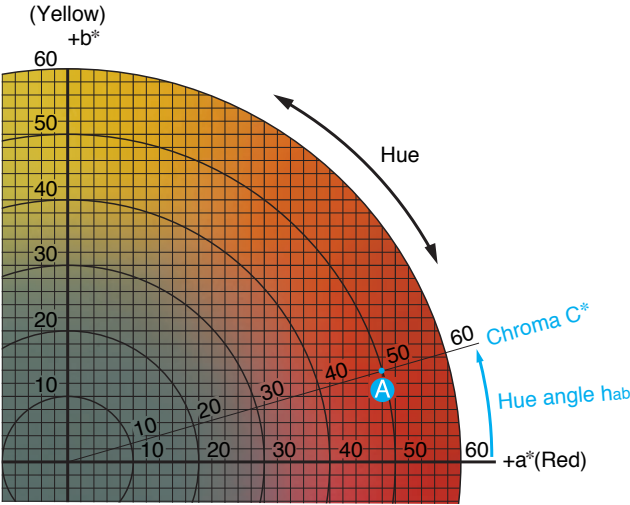

Chroma and lightness

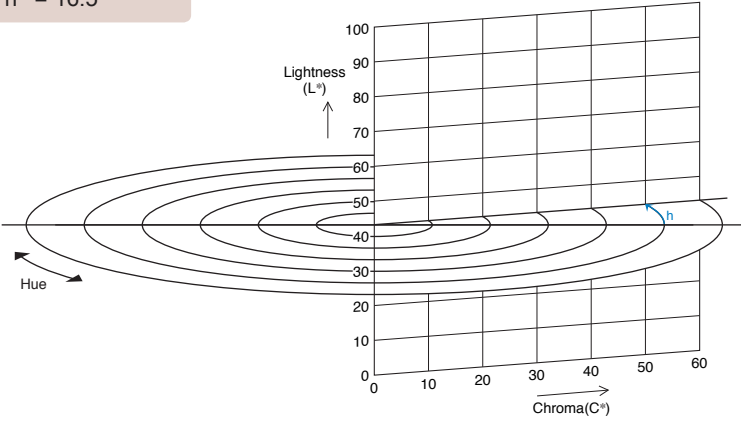

# XYZ Color Space

XYZ tristimulus values and the associated Yxy color space form the foundation of present CIE color spaces. The concept for the XYZ tristimulus values is based on the three-component theory of color vision, which states that the eye possesses receptors for three primary colors (red, green, and blue) and that all colors are seen as mixtures of these three primary colors. The CIE in 1931 defined the Standard Observer to have the color-matching functions,  $\bar{x}(\lambda)$ ,  $\bar{y}(\lambda)$ , and  $\bar{z}(\lambda)$  shown in Figure 10b below. The XYZ tristimulus values are calculated using these Standard Observer color-matching functions.

The tristimulus values XYZ are useful for defining a color, but the results are not easily visualized. Because of this, the CIE also defined a color space in 1931 for graphing color in two dimensions independent of lightness; this is the Yxy color space, in which Y is the lightness (and is identical to tristimulus value Y) and x and y are the chromaticity coordinates calculated from the tristimulus values XYZ (for details, refer to p. 42). The CIE x, y chromaticity diagram for this color space is shown in Figure 10a.

In this diagram, achromatic colors are toward the center of the diagram, and the chromaticity increases toward the edges. If we measure the apple using the Yxy color space, we obtain the values  $x=0.4832$ ,  $y=0.3045$  as the chromaticity coordinates, which correspond to point A on the diagram in Figure 10a; the Y value of 13.37 indicates that the apple has a reflectance of 13.37% (compared to an ideal reflecting diffuser with a reflectance of 100%).



Y = 13.37  
 x = 0.4832  
 y = 0.3045

Figure 10a: xy chromaticity diagram

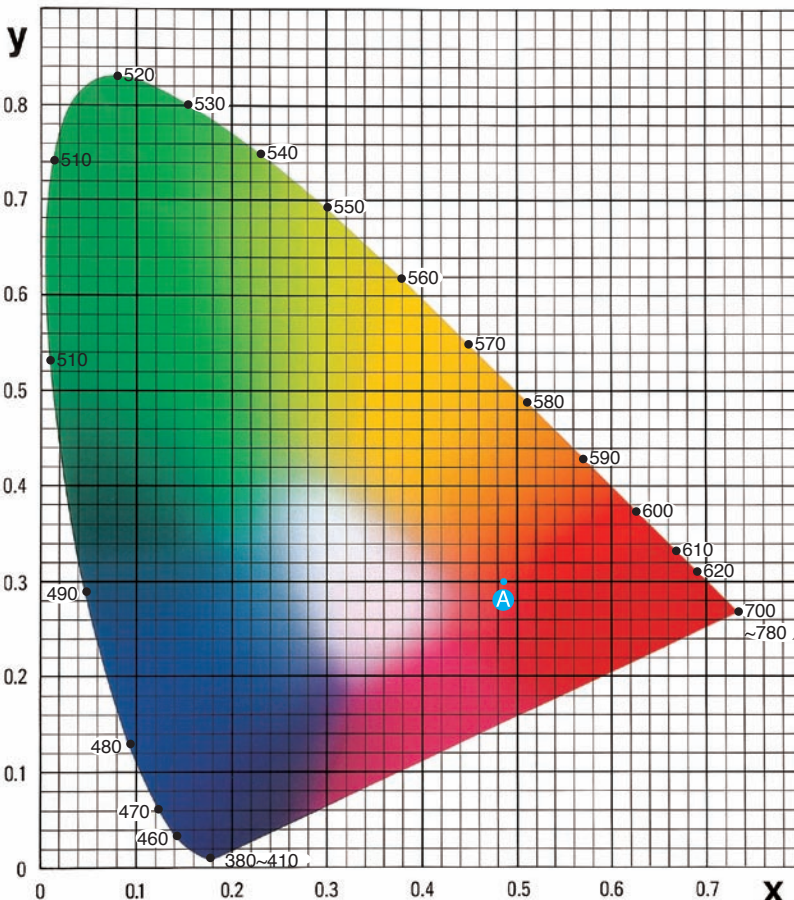
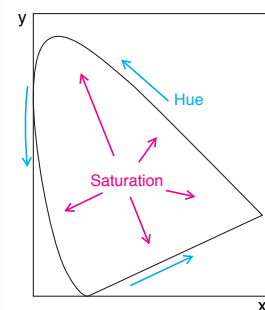
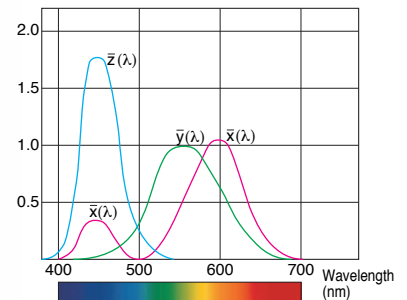
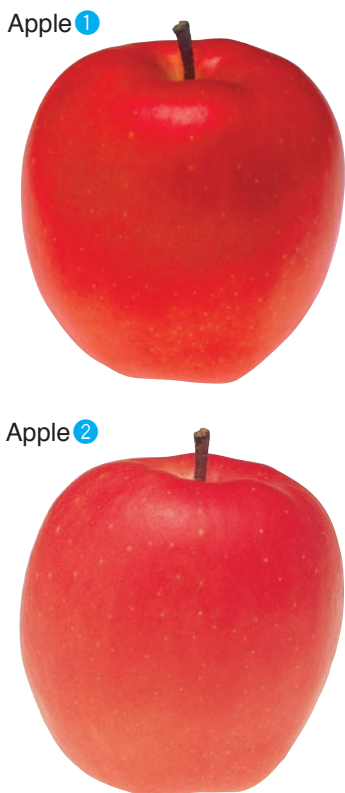

Figure 10b: Spectral response corresponding to the human eye (Color-matching functions of the 1931 Standard Observer)



# Color meters excel at reporting even minute color differences.



## Numerical values show the difference.

Minute color differences are the biggest headache anywhere that color is used. But with a color meter, even minute color differences can be expressed numerically and easily understood. Let's use the L\*a\*b\* and L\*C\*h color spaces to look at the color difference between two apples. Using apple 1's color (L\*=43.31, a\*=+47.63, b\*=+14.12) as the standard, if we measure the difference of apple 2's color (L\*=47.34, a\*=+44.58, b\*=+15.16) from apple 1's color, we get the results shown in display A below. The difference is also shown on the graph in Figure 12. The diagram of Figure 11 should make color difference in the L\*a\*b\* color spaces easier to understand.

A: L\*a\*b\* color difference      B: L\*C\*h\* color difference

$\Delta L^* = +4.03$   
 $\Delta a^* = -3.05$   
 $\Delta b^* = +1.04$   
 $\Delta E^* = 5.16$

$\Delta L^* = +4.03$   
 $\Delta C^* = -2.59$   
 $\Delta H^* = +1.92$   
 $\Delta E^* = 5.16$

Figure 11: Color difference in the L\*a\*b\* color space

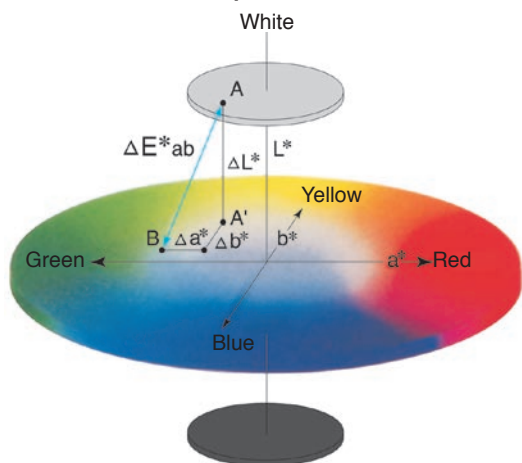

A: Target color  
 B: Specimen color  
 A': Target color at the same lightness as specimen color

In the L\*a\*b\* color space, color difference can be expressed as a single numerical value,  $\Delta E^*_{ab}$ , which indicates the size of the color difference but not in what way the colors are different.  $\Delta E^*_{ab}$  is defined by the following equation

$$\Delta E^*_{ab} = \sqrt{(\Delta L^*)^2 + (\Delta a^*)^2 + (\Delta b^*)^2}$$

If we put the values  $\Delta L^* = +4.03$ ,  $\Delta a^* = -3.05$ , and  $\Delta b^* = +1.04$  from display A above into this equation, we get  $\Delta E^*_{ab} = 5.16$ .

If we measure the color difference between the two apples using the L\*C\*h color space, we get the results shown in display B above. The value of  $\Delta L^*$  is the same as the value measured in the L\*a\*b\* color space.  $\Delta C^* = -2.59$ , indicating that apple 2's color is less saturated. The hue difference between the two apples,  $\Delta H^*$  (defined by the equation  $\Delta H^*_{ab} = \sqrt{(\Delta E^*)^2 - (\Delta L^*)^2 - (\Delta C^*)^2}$ ) is +1.92, which if we look at Figure 12, means that the color of apple 2 is closer to the +b\* axis, and so is more yellow.

• "Δ"(delta) indicates difference

Figure 12: Portion of a\*, b\* chromaticity diagram

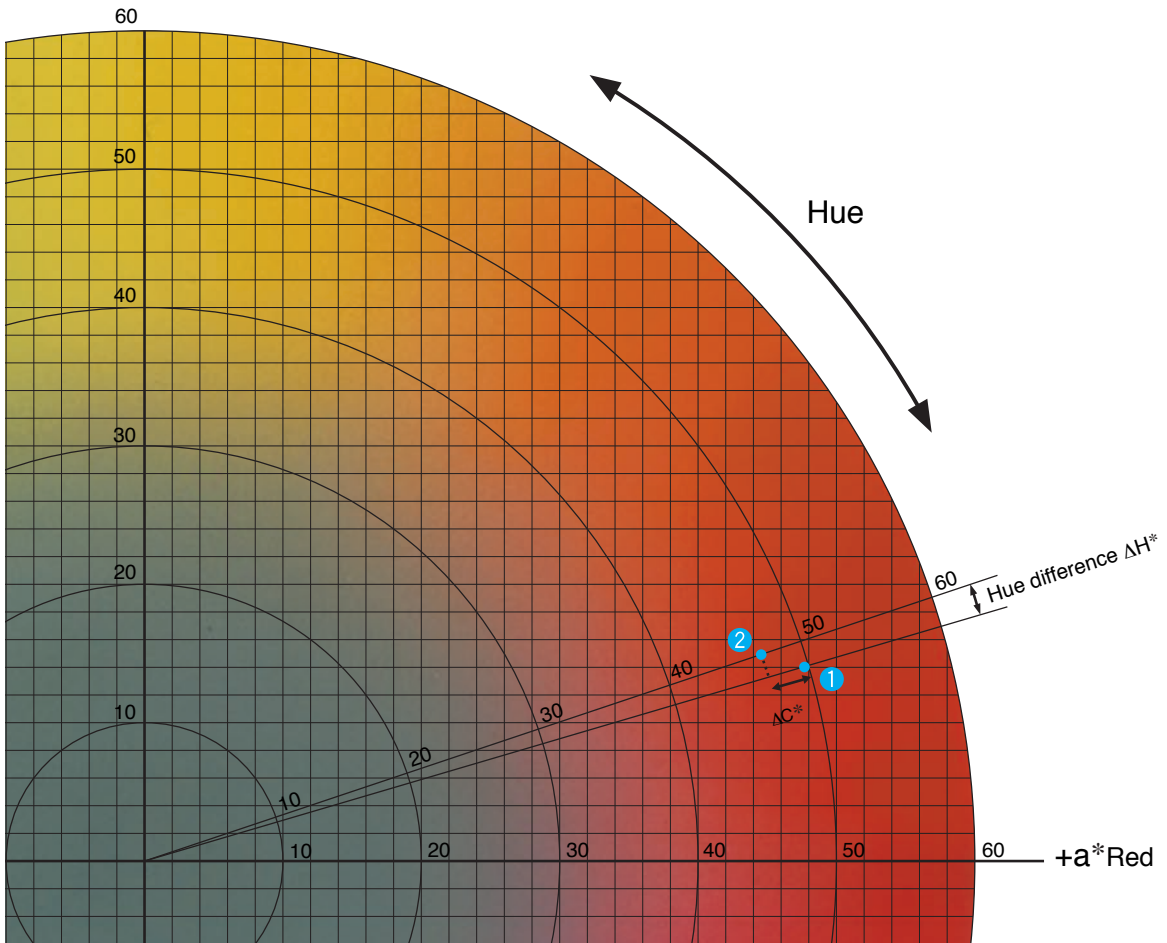

Although words are not as exact as numbers, we can use words to describe color differences. Figure 13, shows some of the terms used to describe differences in lightness and chroma; the terms shown in this figure indicate the direction of color difference, but unless an additional modifier (slightly, very, etc.) is used, they do not indicate the degree of color difference. If we look at the plotted values for the two apples, we see that we should say that the color of apple 2 is “paler” than that of apple 1; since the chroma difference is not very great, we might also add a modifier, saying that apple 2 is “slightly paler” to indicate the degree of difference.

Figure 13: Terms for describing differences in chroma and lightness

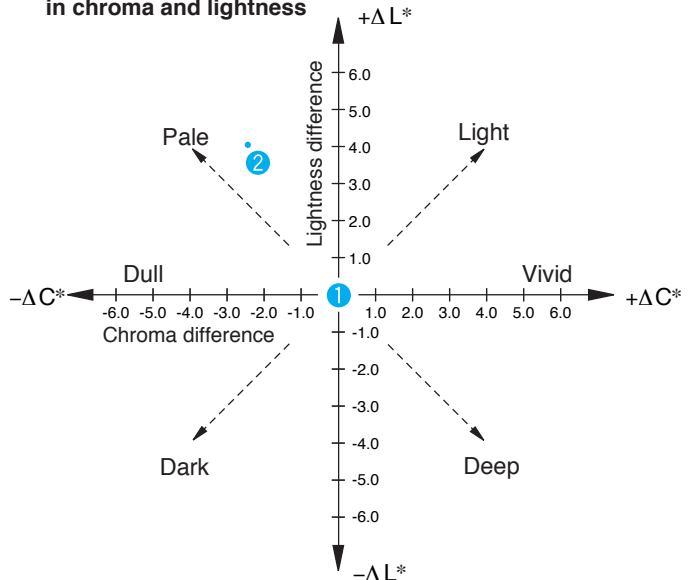



# Even if colors look the same to the human eye, measurements with a color meter can point out slight differences.

Even if two colors look the same to the human eye, as in the example of the two apples on p. 22, slight differences may be found when the colors are measured with a color meter. In addition, the color meter expresses such differences exactly in numerical form. If for some reason the color of a product was wrong and the product was shipped without the problem being noticed, and the customer complained as a result... The effect would not be limited to only the sales department or the production department, it would hurt the reputation of the entire company. Color control plays a very important role in preventing such problems from occurring.

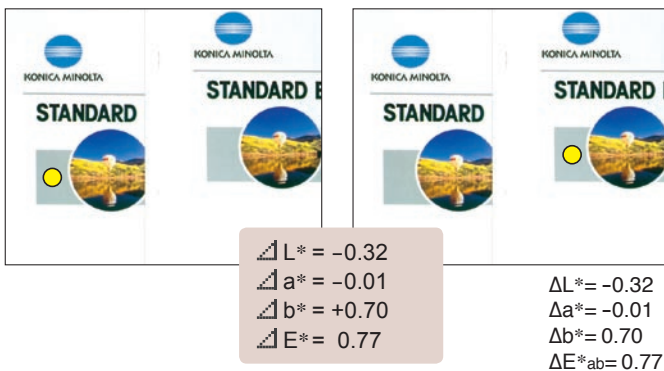

**Color control of printed material**

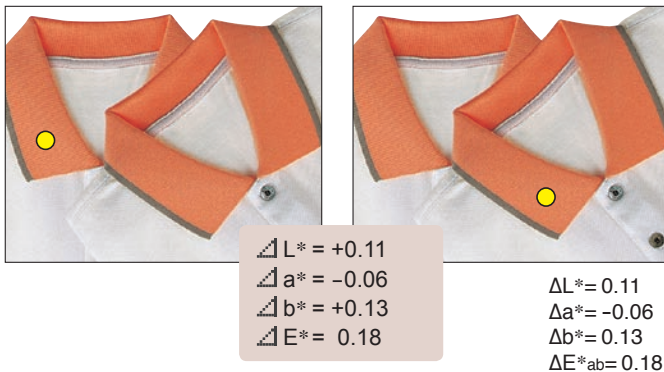

**Color control of textiles**

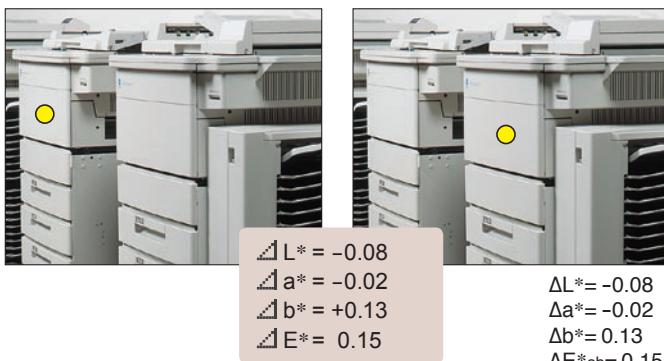

**Color control of plastic products**

● indicates the measurement point.

## An example of quality control using a color meter.

**Let's look at how useful a color meter can be for color control.**

Company K manufactures exterior plastic parts ordered by company B. Company B also orders similar parts from companies other than Company K. At Company K, a full-time staff of inspectors is in charge of controlling color on the production line and visually evaluates products in comparison to color samples. Visual inspection depends on the eyes of skilled inspectors to determine whether or not a product is within the acceptance range as defined by the color samples. This work cannot be performed by anyone; it requires years of experience to develop an ability for visual inspection. As a result, the number of people who can do this work is limited. Also, the process can be performed only for a limited period of time per day or week, and the evaluation will vary according to the inspector's age and physical condition. Sometimes, company K complained that the color of parts delivered by Company K did not match those of other suppliers and so company B returned the parts to Company K. Company K decided to utilize color meters for color control of its products on the production line. The color meters became very popular, because they were handheld and could be used even on the production line, they were easy enough for anyone to use, and measurements were quick so they could be used at any time. Further, the data measured by the color meter were submitted with the products at the time of delivery as proof of the company's quality control.





# **Basic Knowledge for Spectrophotometer Selection**

So far we understand that using color meters enables expressing colors numerically to ensure smooth and easy color communication as well as to analyze colors from various angles. Let's study more about the special colors and conditions that influence the selection of color meters.

# Differences in the color recognition process between the human eye and color meters

We can see the light from wavelengths in the visible light region; however, light is not a color in itself. As the definition specifies "the radiant energy which can stimulate the retina in the eye to produce a sense of sight", the concept of "color" is formed when light enters the eye and stimulates the retina, and the brain reacts to it.

Among the colors of the spectrum (red, orange, yellow, green, etc.), three colors of red, green, and blue are generally described as the three primary colors of light. It is believed that we can perceive colors because the eye has three types of cones (color sensors) which are sensitive to these three primary colors. Figure 14 shows the spectral response curves corresponding to the human eye, according to the CIE definition of the 1931 Standard Observer. These are referred to as the color-matching functions.  $\bar{x}(\lambda)$  has a high response in the red wavelength region,  $\bar{y}(\lambda)$  has a high response in the green wavelength region, and  $\bar{z}(\lambda)$  has a high response in the blue wavelength region. The colors that we see are the result of different  $\bar{x}(\lambda)$ ,  $\bar{y}(\lambda)$ , and  $\bar{z}(\lambda)$  proportions (stimuli) in the light received from an object.

## Tristimulus method and spectrophotometric method

As shown in Figure 15b, the tristimulus method measures the light reflected from the object using three sensors filtered to have the same response to  $\bar{x}(\lambda)$ ,  $\bar{y}(\lambda)$ , and  $\bar{z}(\lambda)$  as the human eye and thus directly measures the tristimulus values X, Y, and Z. On the other hand, the spectrophotometric method shown in Figure 15c utilizes a diffraction grating to separate the light reflected from the object into a spectrum, and then uses multiple sensors (40 in the CM-2600d) to measure the spectral reflectance at each wavelength or in each narrow wavelength range. The instrument's microcomputer then calculates the tristimulus values from the spectral reflectance data by performing integration. For the apple used in the example, the tristimulus values are X=21.21, Y=13.37, and Z=9.32; These tristimulus values can then be used to calculate values in other color spaces such as Yxy or L\*a\*b\*. Figure 16 shows how the tristimulus values X, Y, and Z are determined. Light with spectral

Figure 14: Spectral response corresponding to the human eye

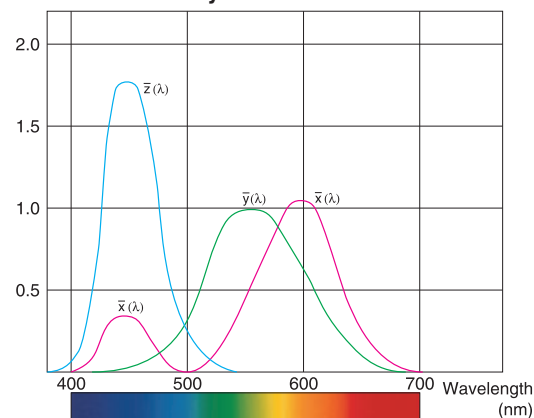
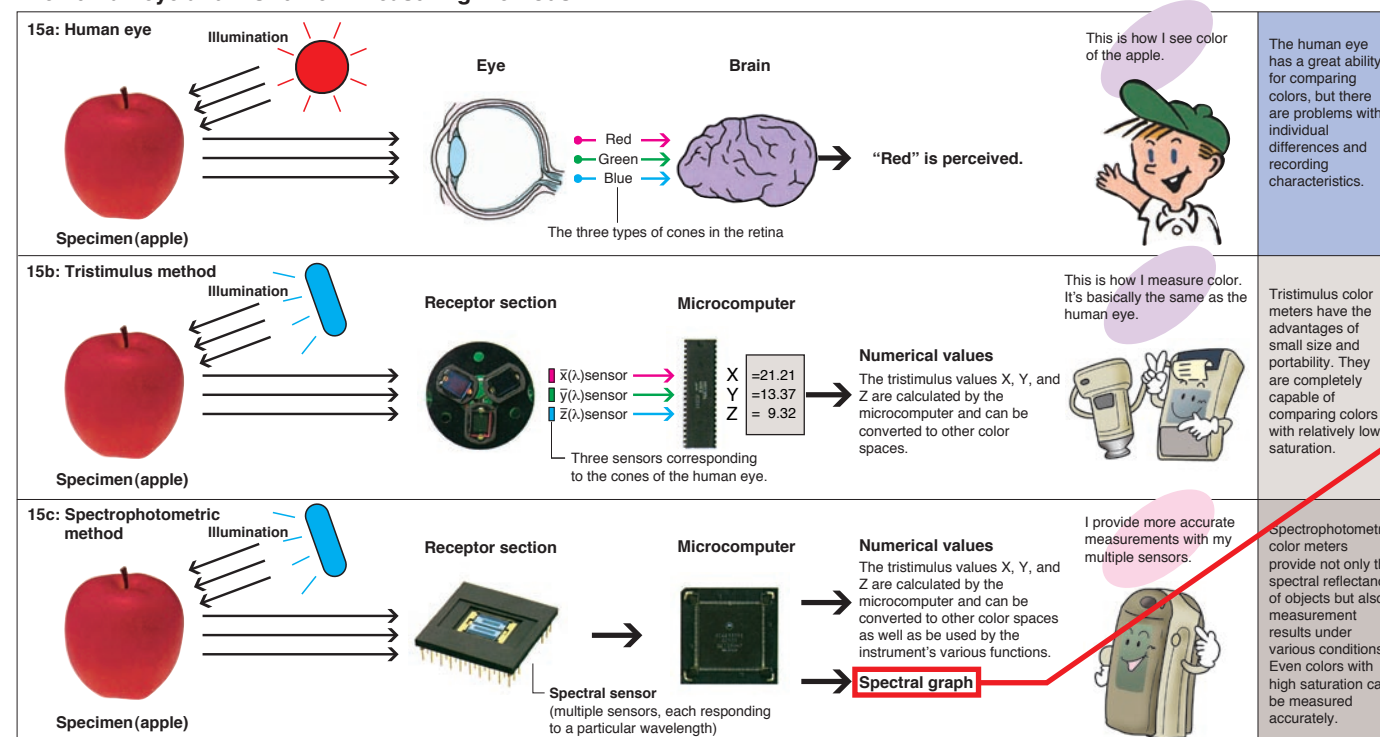
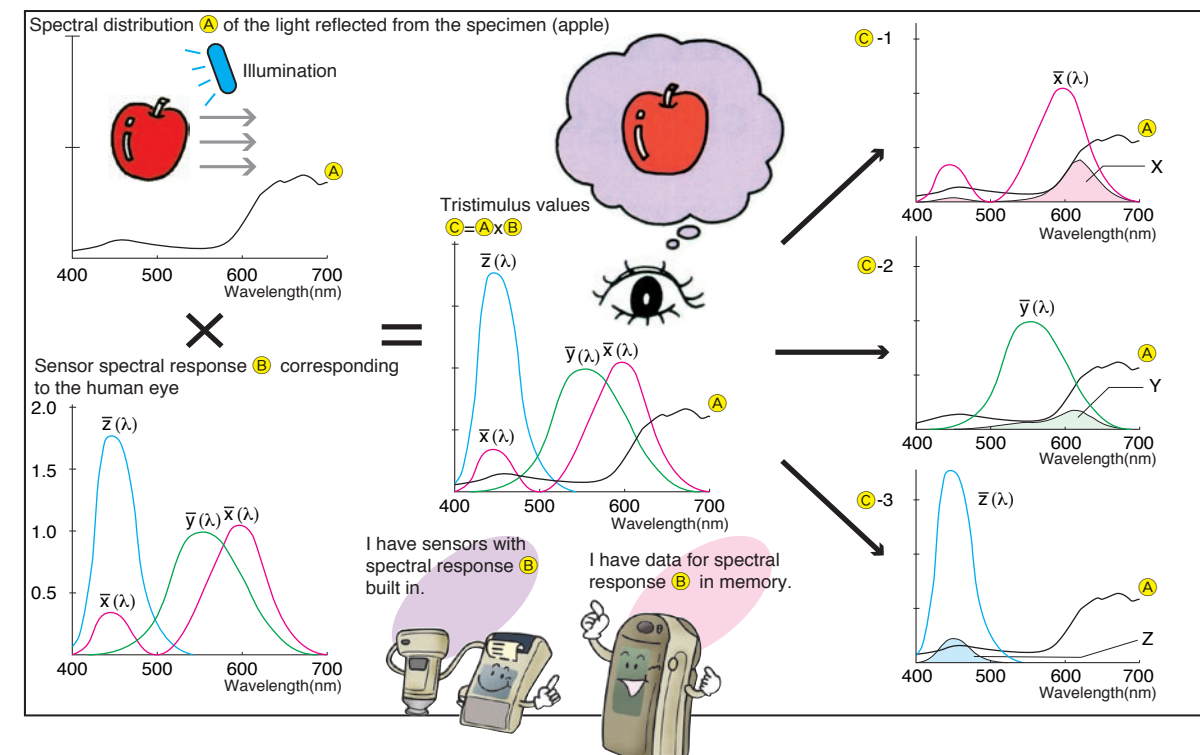

Figure 15: The human eye and instrument measuring methods



distribution **A** reflected by the specimen (apple) is incident on sensors with spectral response **B**, whose filters divide the light into wavelength regions corresponding to the three primary colors and the sensors output the tristimulus values (X, Y, and Z) **C**. Thus,  $C = A \times B$ . The results in the three wavelength regions of **C** are also shown: **C**-1:  $\bar{x}(\lambda)$ , **C**-2:  $\bar{y}(\lambda)$ , and **C**-3:  $\bar{z}(\lambda)$ . The tristimulus values are equal to the integrations of the shaded area in the three graphs.

Figure 16: Determination of the tristimulus values in color measurements



## Spectral reflectance graph

In addition to displaying numerical color data, a spectrophotometer can also display a graph of the color's spectral reflectance. Colors are created by mixing various wavelengths of light in appropriate proportions. A color meter using the tristimulus method only indicates the position of the target color in the chromaticity diagram of various color spaces. A spectrophotometer separates the light reflected from an object with a diffraction grating, measures spectral reflectance at each wavelength or in each wavelength range by using multiple sensors, and then displays the data on a graph.

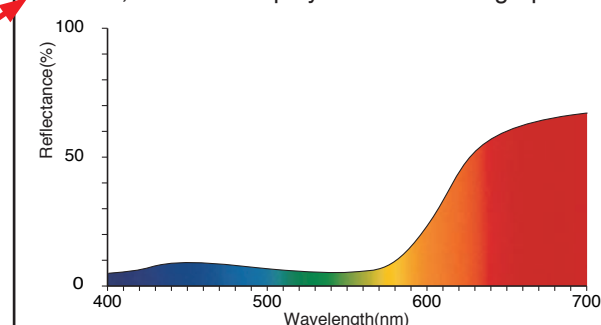

# What about the components of light (and color)? Let's take a look.

An object absorbs part of the light from the light source and reflects the remaining light. This reflected light enters the human eye, and the resulting stimulation of the retina is recognized as the object's "color" by the brain. Each object absorbs and reflects light from different portions of the spectrum and in different amounts; these differences in absorptance and reflectance are what make the colors of different objects different.



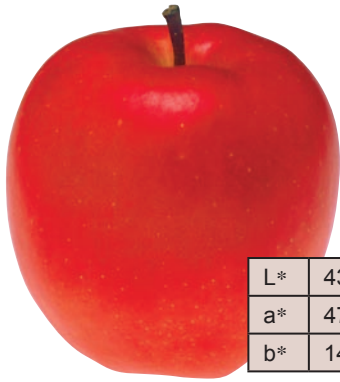

**Apple**

|    |       |
|----|-------|
| L* | 43.31 |
| a* | 47.63 |
| b* | 14.12 |

If we measure an apple, we obtain the spectral graph shown in Figure 17a. If we look at this graph, we see that in the red wavelength region the reflectance (the amount of reflected light) is high, but in other wavelength regions the reflectance (the amount of reflected light) is low. Figure 17b shows that the apple reflects light in the orange and red wavelength regions and absorbs light in the green, blue, indigo, and violet wavelength regions. In this way, by taking a measurement with a spectrophotometer and displaying the results on a spectral graph, we can see the nature of the apple's color. Each of the multiple sensors (40 in the Konica Minolta Spectrophotometer CM-2600d) of a spectrophotometer measures light in a strictly defined wavelength region of the visible-light wavelength range. Because of this, the spectrophotometer can measure differences in the elements of color which are not noticeable to the human eye.

**Figure 17a:**  
Spectral reflectance graph for an apple

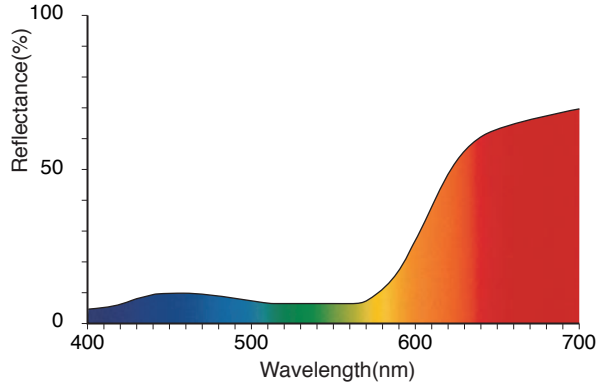

**Figure 17b:**

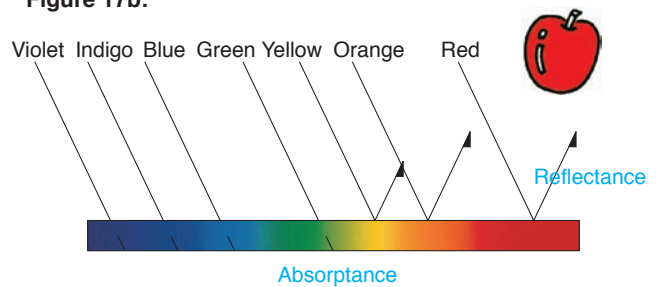

**Figure 18a:**  
Spectral reflectance graph for a lemon

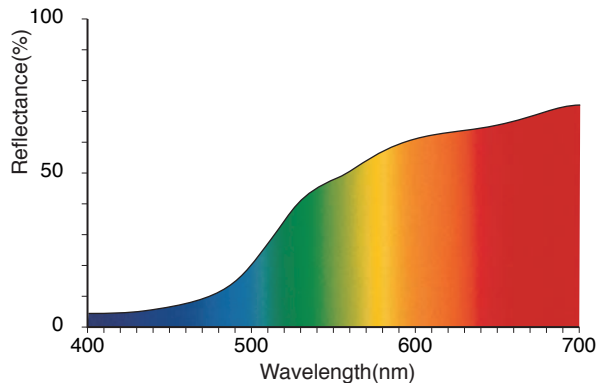

**Figure 18b:**

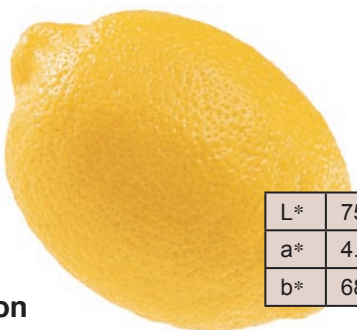
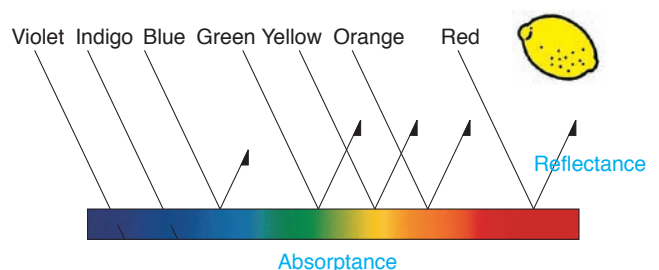

**Lemon**

|    |       |
|----|-------|
| L* | 75.34 |
| a* | 4.11  |
| b* | 68.54 |

If we measure a lemon, we obtain the spectral graph shown in Figure 18a. If we look at this graph, we see that in the red and yellow wavelength regions the reflectance (the amount of reflected light) is high, but in the indigo and violet wavelength regions the reflectance (the amount of reflected light) is low. Figure 18b shows that the lemon reflects light in the green, yellow, and red wavelength regions and absorbs light in the indigo and violet wavelength regions. This is the nature of the lemon's color.

# Let's measure various colors with a color meter.

With a color meter, we can obtain numerical color data in various color spaces. If we use a spectrophotometer for measurements, not only can we obtain the same types of numerical data, but we can also see the spectral reflectance graph for that color. Further, with its high-precision sensors and the inclusion of data for a variety of illumination conditions, a spectrophotometer can provide numerical color data using various light sources.

## A: Tile

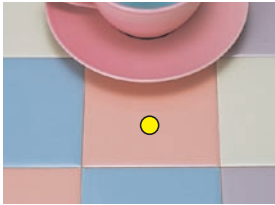

● indicates the measurement point.

|    |       |
|----|-------|
| L* | 74.72 |
| a* | 15.34 |
| b* | 10.21 |

A pink tile was measured. By looking at the spectral reflectance graph, we can see that the tile reflects light at all wavelengths, and that the spectral reflectance in the wavelength regions above 600nm (the orange and red regions) is a bit higher than that of other wavelength regions.

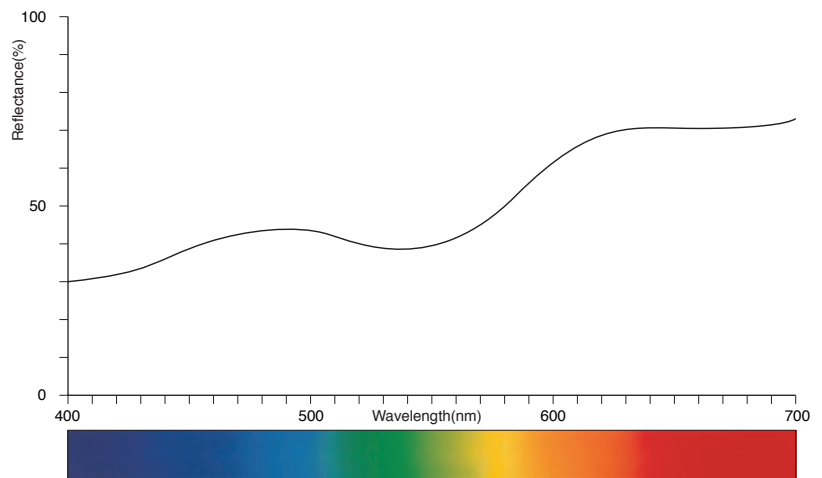

## B: Textiles



● indicates the measurement point.

|    |        |
|----|--------|
| L* | 64.51  |
| a* | -36.87 |
| b* | 54.69  |

The green area of the cloth was measured. The spectral reflectance over the entire wavelength range is low, showing a peak of around 520nm. The spectral reflectance is low at a wavelength of 450nm or lower and at 600nm or higher, indicating that blue and red light was absorbed.

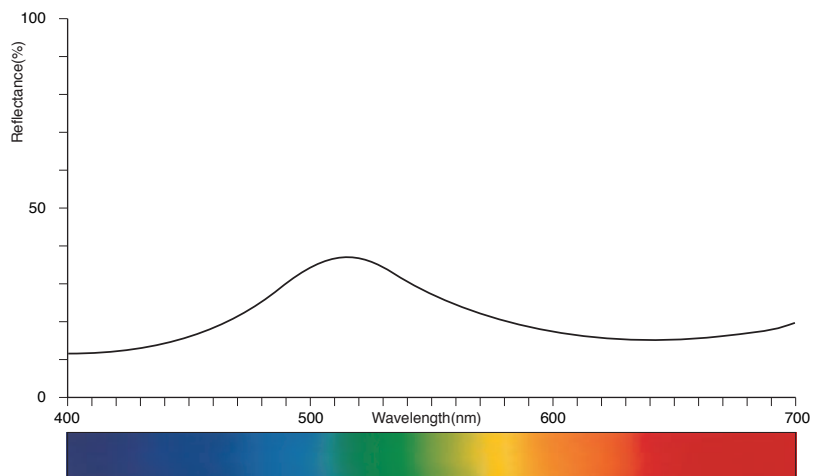



### C: Plastic

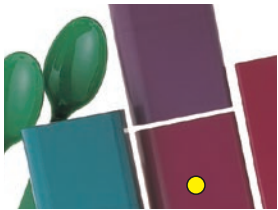

● indicates the measurement point.

|    |        |
|----|--------|
| L* | 34.27  |
| a* | 44.53  |
| b* | -21.92 |

A reddish purple plastic part was measured. The regions around 400nm and 700nm have high spectral reflectance, and the wavelength region from 500 to 600nm has low spectral reflectance and we can see that the light is absorbed.

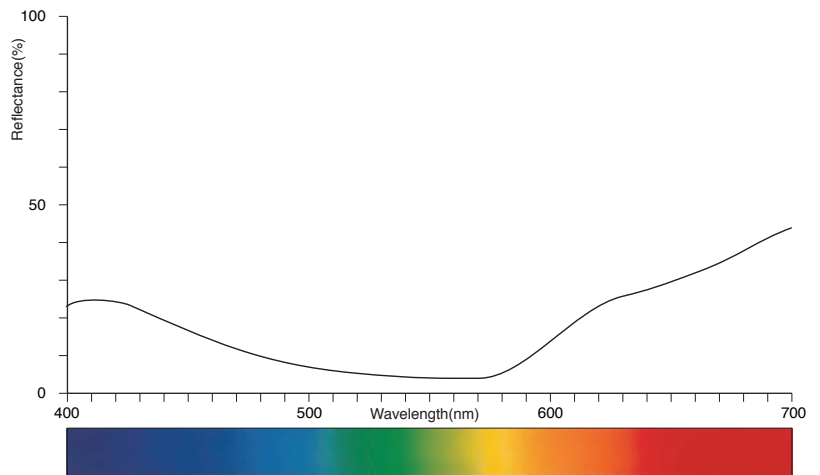

### D: Rubber



● indicates the measurement point.

|    |        |
|----|--------|
| L* | 37.47  |
| a* | 7.07   |
| b* | -47.77 |

This is a vivid blue. The spectral reflectance in the wavelength region from 400 to 500nm (the indigo and blue regions) is high, and the spectral reflectance for wavelengths longer than 550nm is low, with almost all light in this region being absorbed.

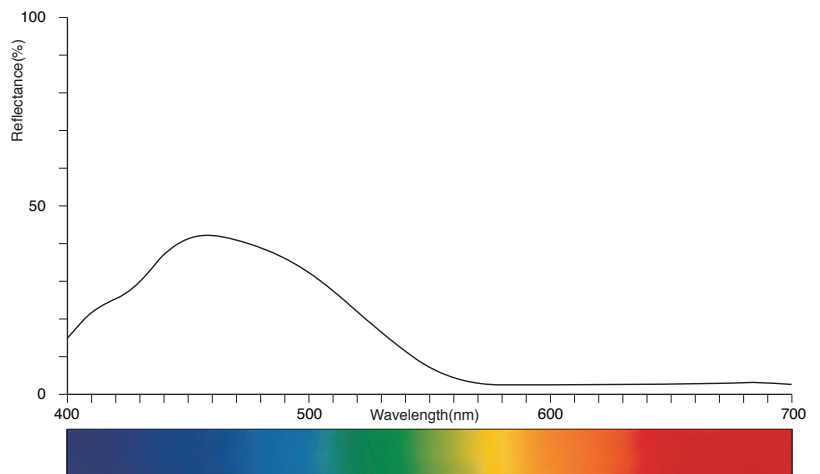

# Even though it's actually the same color, it looks different. Why?

Now we understand that color meters can express colors numerically, and spectrophotometers can provide a spectral reflectance graph for the colors. Such numerical data and graphs are effective for color communication, however, there are other color-related problems in color management, and color meters are also useful to solve these problems.

For example, you may have experienced that the same color looks different under different light sources.

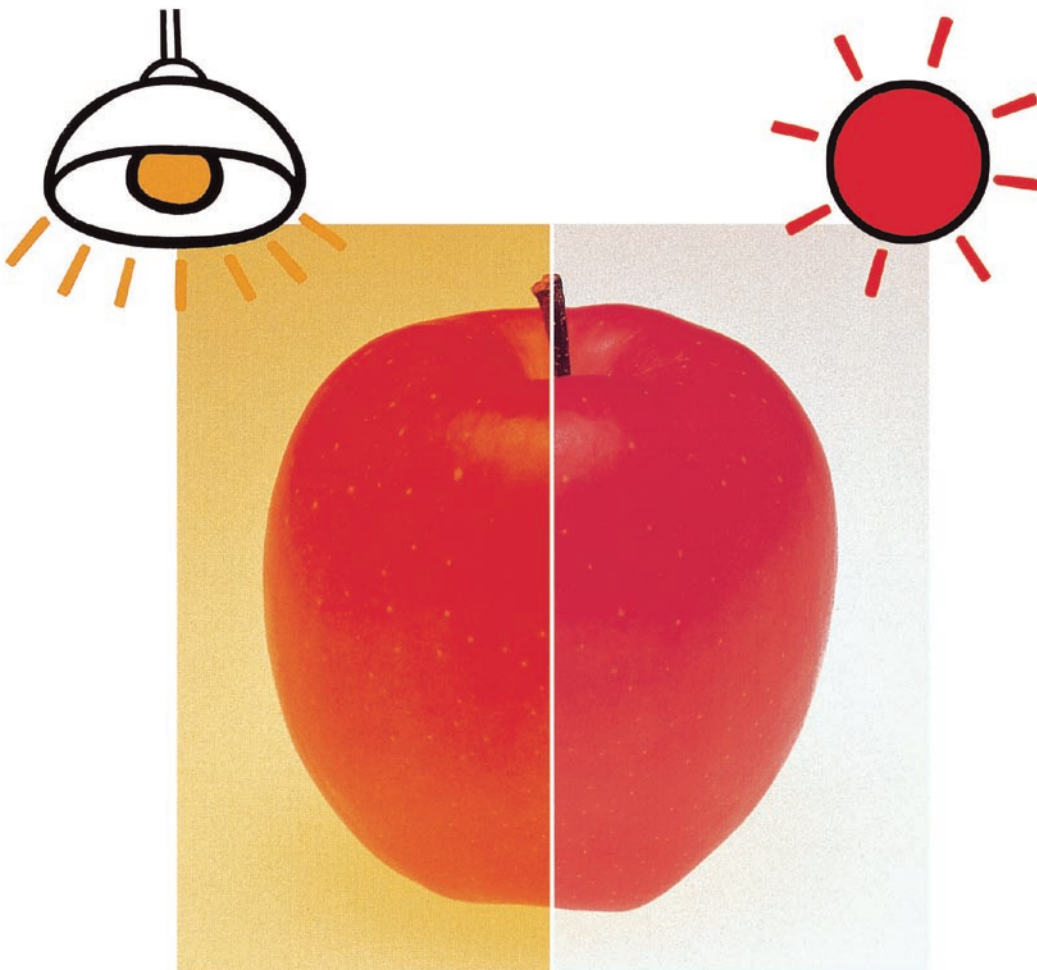

# A variety of conditions affect how a color looks.

## Light-source differences

An apple which looks so delicious under sunlight in front of the green grocer somehow doesn't look so good under the fluorescent lights at home. Probably many people have had such an experience. Sunlight, fluorescent light, tungsten light, etc.; each type of illumination will make the same apple look different.

## Subject condition and environmental differences

### Surface condition differences

For example, when sandpaper is applied to the surface of a smooth plastic plate, the color looks duller. Even objects with the same color look different due to the difference in the surface condition.

### Observing direction or illumination position differences

In general, viewing an object from just a slightly different angle can make the object appear brighter or darker. This is due to the directional characteristics of the object, which are especially obvious with translucent or metallic colors. The angle from which the object is viewed, and also the angle from which it is illuminated, must be constant for accurate color communication.

## Optical illusion; and individual differences

### Size differences

After looking at small sample pieces and selecting a wallpaper which looks good, people sometimes find that it looks too bright when it's actually hung on the wall. Colors covering a large area tend to appear brighter and more vivid than colors covering a smaller area. This is referred to as area effect. Selecting objects which will have a large area based on color samples having a small area may result in mistakes.

### Background differences

If the apple is placed in front of a bright background, it will appear duller than when it is placed in front of a dark background. This is referred to as contrast effect, and is undesirable for accurately judging color.

### Observer differences

The sensitivity of each individual's eyes is slightly different; even for people considered to have "normal" color vision, there may be some bias toward red or blue. Also, a person's eyesight generally changes with age. Because of these factors, colors will appear differently to different observers.

It's important to keep conditions constant when viewing colors.



# Colors look different according to the light source.

Different light sources will make colors appear different. Although color meters (both tristimulus type and spectrophotometric type) have built-in illumination, it is not enough for accurate color measurement. Consequently, the CIE and JIS have defined the spectral characteristics of several different types of typical illuminants. Figure 19 shows the spectral power distributions of some of these illuminants. A light source is usually built into the color-measuring instrument. This light source may or may not match any of the CIE illuminants; instead, the instrument determines the data for measurements under the selected illuminant through calculations based on the data actually measured under the instrument's light source and the illuminant's spectral distribution data stored in the instrument's memory.

## Figure 19a: Standard Illuminants

- 1 Standard Illuminant D65: Average daylight (including ultraviolet wavelength region) with a correlated color temperature of 6504K; should be used for measuring specimens which will be illuminated by daylight including ultraviolet radiation.
- 2 Standard Illuminant C: Average daylight (not including ultraviolet wavelength region) with a correlated color temperature of 6774K; should be used for measuring specimens which will be illuminated by daylight in the visible wavelength range but not including ultraviolet radiation.
- 3 Standard Illuminant A: Incandescent light with a correlated color temperature of 2856K; should be used for measuring specimens which will be illuminated by incandescent lamps.

## Figure 19b: Fluorescent Illuminants (recommended by CIE for measurements)

- 4 F2: Cool white
- 5 F7: Daylight
- 6 F11: Three narrow band cool white

## Figure 19c: Fluorescent Illuminants (recommended by JIS for measurements)

- 7 F6: Cool white
- 8 F8: Daylight white
- 9 F10: Three narrow band daylight white

Figure 19: Spectral Distribution of CIE Illuminants

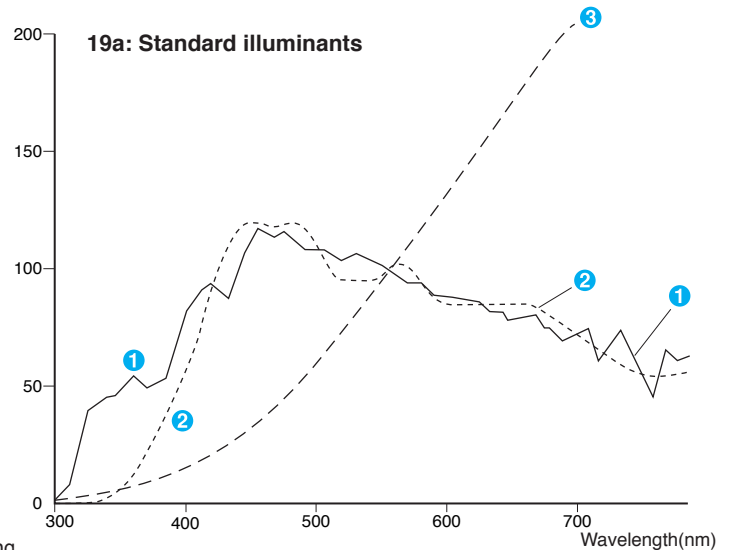

19b: Fluorescent illuminants (recommended by CIE for measurements)

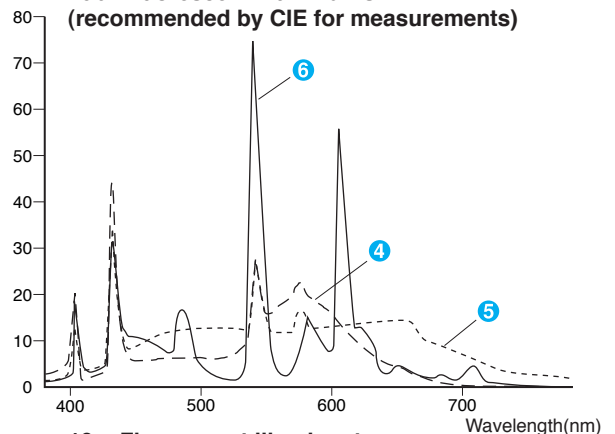

19c: Fluorescent illuminants (recommended by JIS for measurements)

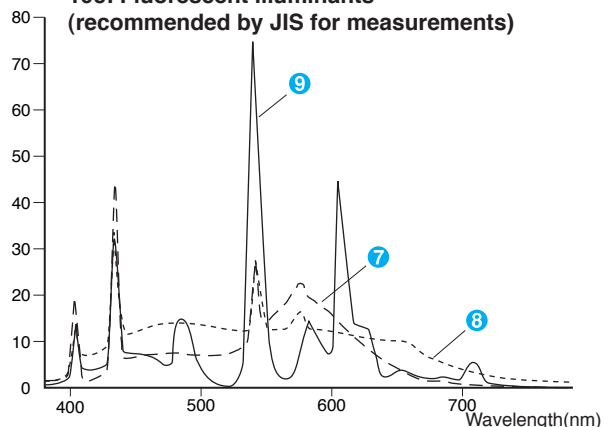

I only have data for 1 and 2

I have data for all of them from 1 to 9



Let's look at examples of what happens if we measure our specimen (apple) using a spectrophotometer under Standard Illuminant D<sub>65</sub> (example 1) and Standard Illuminant A (example 2).

In example 1, **A** is the graph of the spectral power distribution of Standard Illuminant D<sub>65</sub> and **B** is a graph of the spectral reflectance of the apple. **C** is the spectral power distribution of the light reflected from the specimen (apple) and is the product of **A** and **B**. In example 2, **A'** is the spectral power distribution of Standard Illuminant A and **B** is the spectral reflectance of the specimen (apple), which is the same as in example 1.

**C'** is the spectral power distribution of the light reflected from the specimen (apple) and is the product of **A'**, and **B**. If we compare **C** and **C'**, we notice that the light in the red region is much stronger in **C'**, meaning that the apple would appear much redder under Standard Illuminant A. This shows that the color of a subject changes according to the light under which it is viewed. A spectrophotometer actually measures the spectral reflectance of the specimen; the instrument can then calculate numerical color values in various color spaces using the spectral power distribution data for the selected illuminant and data for the color-matching functions of the Standard Observer.

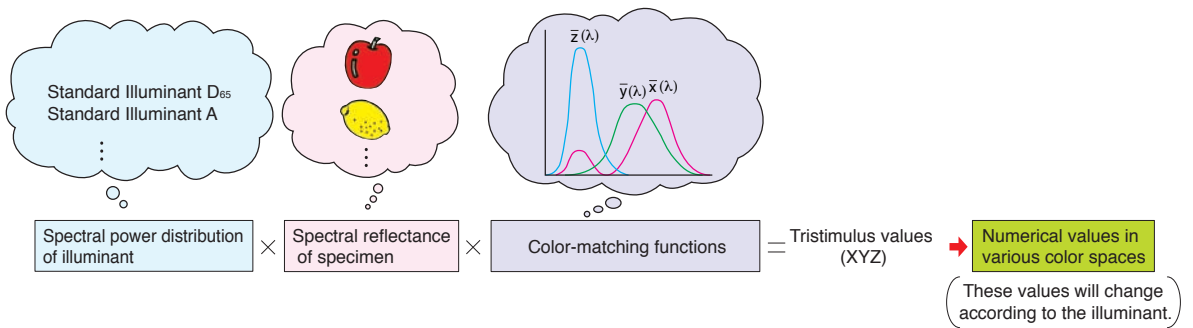

**Example 1**

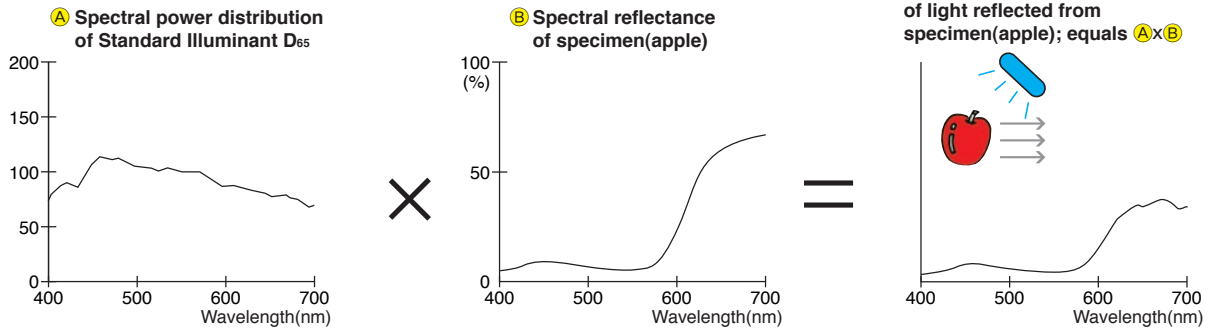

**Example 2**

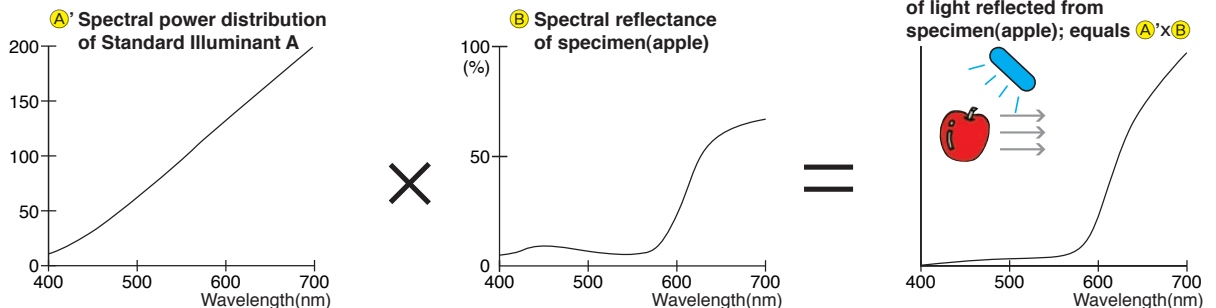

# A complex problem: Metamerism

So far, we discussed how the color of an object depends on the light source under which it is viewed. A related problem is, for example, when the colors of two objects appeared to be the same under daylight but appeared to be different under indoor room lighting. Such a phenomenon, in which two colors appear the same under one light source but different under another, is called metamerism. For metameric objects, the spectral reflectance characteristics of the colors of the two objects are different, but the resulting tristimulus values are the same under one light source and different from each other under another. This problem is often due to the use of different pigments or materials. Look at Figure 20. If we look at the spectral reflectance curves for the two specimens, we can immediately see that they are different. However, the  $L^*a^*b^*$  values for measurements under Standard Illuminant  $D_{65}$  are the same for both specimens, but the values for measurements under Standard Illuminant A are different from each other. This shows that even though the two specimens have different spectral reflectance characteristics, they would appear to be the same color under daylight (Standard Illuminant  $D_{65}$ ). So how should metamerism be handled? To evaluate metamerism, it is necessary to measure the specimens under two or more illuminants with very different spectral power distributions, such as Standard illuminant  $D_{65}$  and Standard Illuminant A. Although both tristimulus colorimeters and spectrophotometers use a single light source, they can calculate measurement results based on illuminant data in memory to provide data for measurements under various illuminants. Tristimulus colorimeters can generally take measurements under only Standard Illuminant C and Standard Illuminant  $D_{65}$ , both of which represent daylight and which have very similar spectral power distributions; because of this, tristimulus colorimeters cannot be used to measure metamerism. The spectrophotometer, on the other hand, is equipped with the spectral power distributions of a wide range of illuminants and thus can determine metamerism. Moreover, with the spectrophotometer's capability to display spectral reflectance graphs, you can see exactly how the spectral reflectances of the two colors are different.

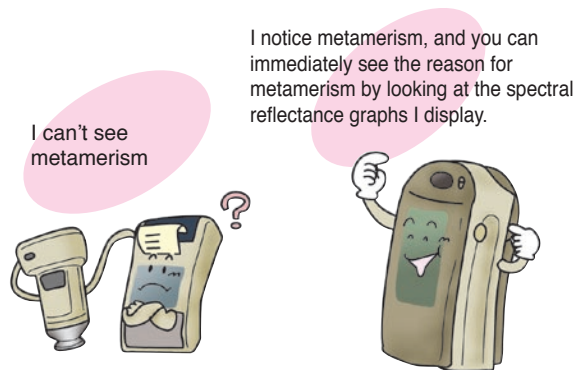

**Figure20: Metamerism**

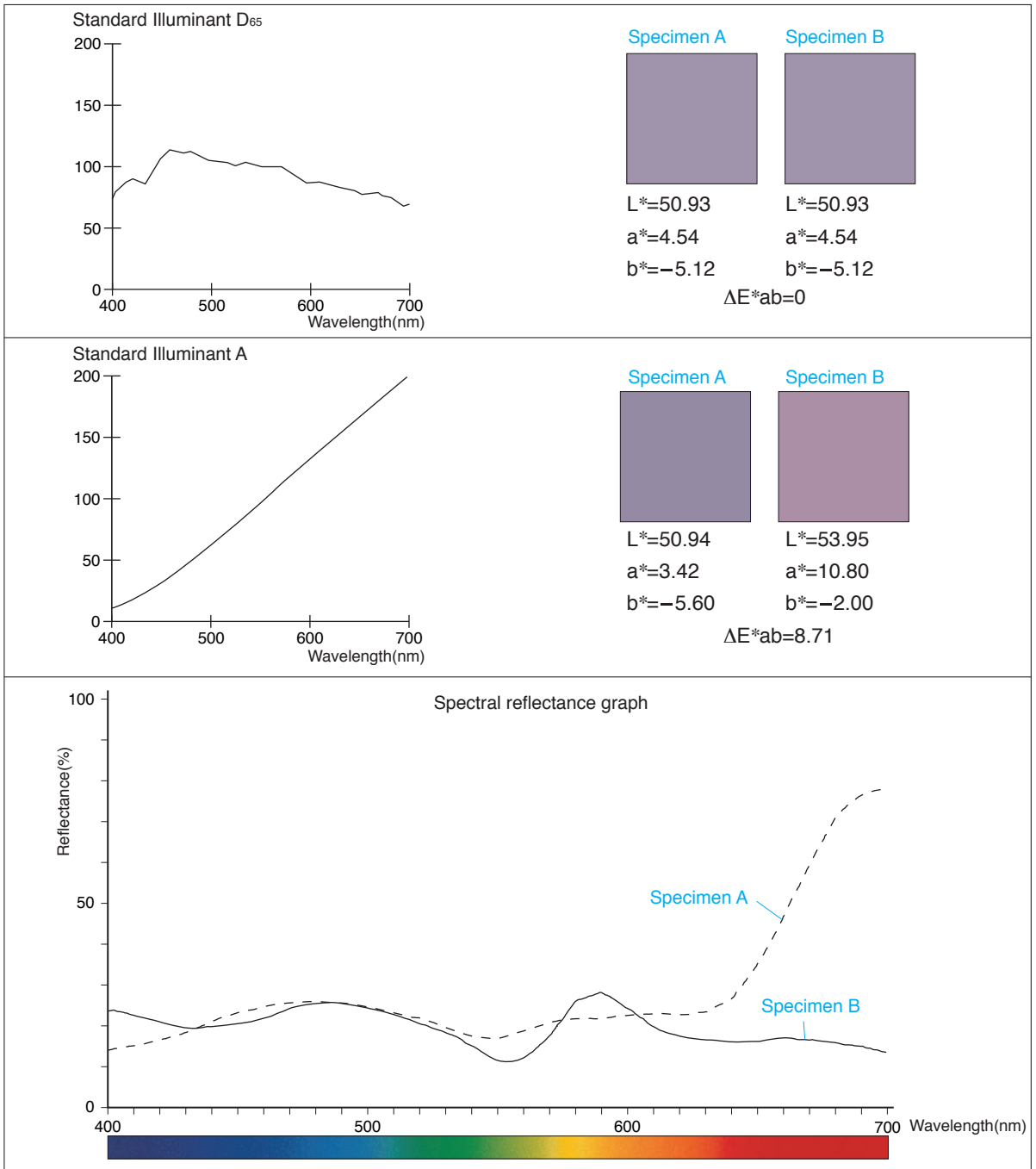

•The colors may not be reproduced exactly in this booklet due to the limitations of the printing process.

# Colors also look different according to the subject conditions and environment.

## Surface condition differences

Even for objects composed of the same materials, variances may be seen in the colors due to differences in the gloss of the surfaces. For example, when sandpaper is applied to a shiny or high gloss blue plastic sample, the color appears as a duller blue. This is because the application of sandpaper changes the surface condition, resulting in diffuse reflection of light.

### < Specular reflection and diffuse reflection >

When a ball bounces on a wall and returns, it bounces and returns at the same angle. In the same manner, the light which reflects at the equal but opposite angle from the light source is called the specularly reflected light. This specular component is reflected as if reflected by a mirror. The light that is not specularly reflected, but scattered in many directions, is called diffuse reflectance. The sum of the specular reflectance plus the diffuse reflectance is called the total reflectance.

For objects with shiny surfaces, the specularly reflected light is relatively strong and the diffused light is weaker. On rough surfaces with a low gloss, the specular component is weak and the diffused light is stronger. When a person views a blue plastic object with a shiny surface at the specular angle, the object does not appear to be as blue. This is because the mirror-like reflection from the light source is added to the color of the sample. Usually, a person looks at the color of an object and ignores the specular reflection of the light source. To measure the color of a specimen in the same manner that it is viewed, the specular reflection must be excluded and only the diffuse reflection must be measured. The color of an object can appear different because of differences in the level of specular reflection.

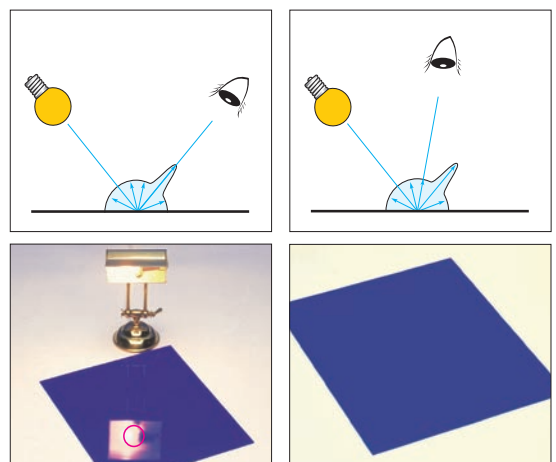
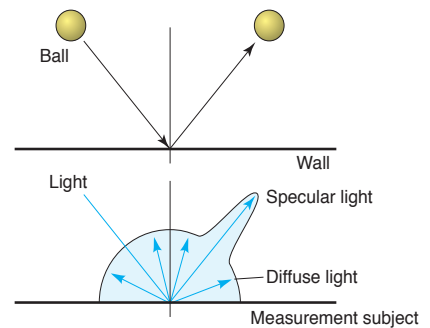
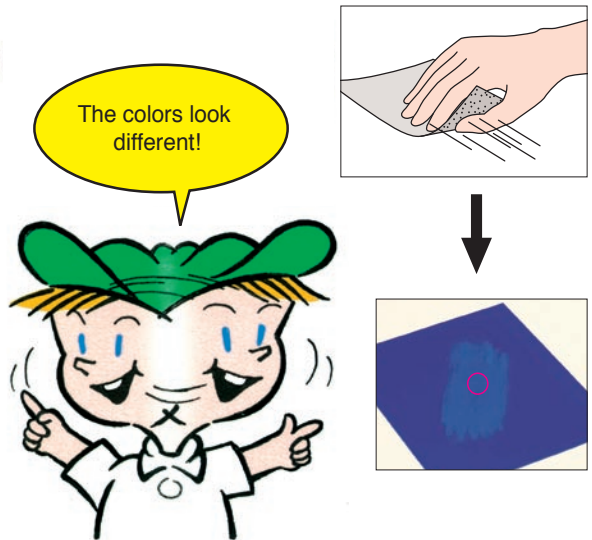



## < SCE (Specular Component Excluded) mode and SCE (Specular Component Included) mode >

People recognize the color of an object by viewing the diffuse reflection. If the surface condition of an object is changed, the color of the surface looks different, but the color of the material should be the same. How can we recognize the color of the material?

There are two types of diffuse reflection: Reflection from the inside of an object and reflection from the surface of an object.

When the surface condition of an object changes, the diffuse reflection from the inside does not change whereas the diffuse reflection from the surface changes, resulting in the change in the amount of specular reflection and diffuse reflection. Even

in such a case, the total amount of the specular and diffuse reflection from the surface is always the same. Therefore, if a glossy blue plastic part is sanded, the specular reflection decreases and the diffuse reflection increases. Consequently, you can measure the color of the material regardless of the surface condition by measuring the total reflection (specular plus diffuse).

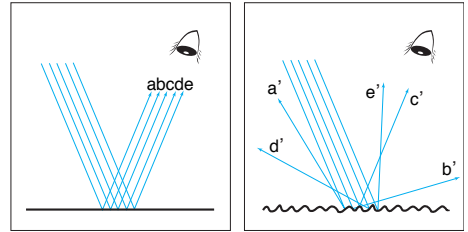

These figures indicate that  $a+b+c+d+e=a'+b'+c'+d'+e'$ .

The positions of the light trap in Conditions III (SCE) and IV (SCE), as displayed in Figure 21 on the next page, show how the specular reflection is excluded from the color measurement of the specimen. If this trap is replaced with a white plug, as in Conditions V (SCI) and VI (SCI), the specular reflection will be included in the color measurement. The method of color measurement which excludes the specular reflection is called SCE (Specular Component Excluded). If the specular reflection is included in the color measurement, by completing the sphere with a specular plug, it is called SCI (Specular Component Included).

In the SCE mode, the specular reflection is excluded from the measurement and only the diffuse reflection is measured. This produces a color evaluation, which correlates to the way the observer sees the color of an object. The 45°:n and n:45° systems produce a result similar to the SCE mode because the instrument does not receive specular reflection.

When using the SCI mode, the specular reflection is included with the diffuse reflection during the measurement process. This type of color evaluation measures total appearance independent of surface conditions.

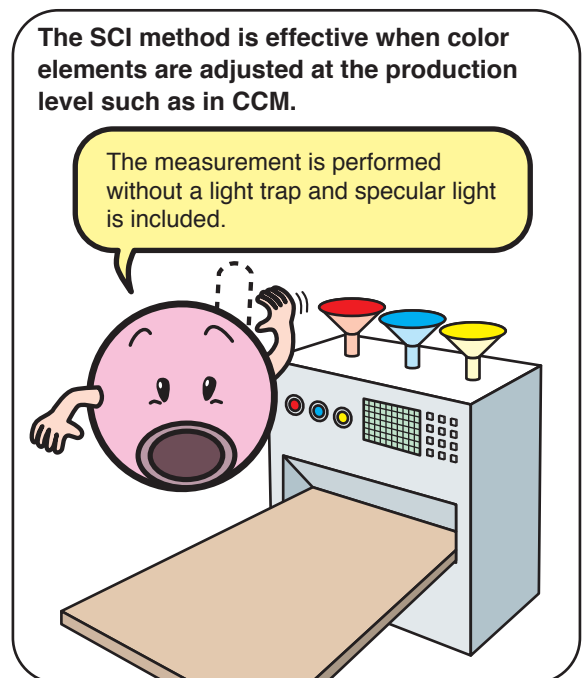
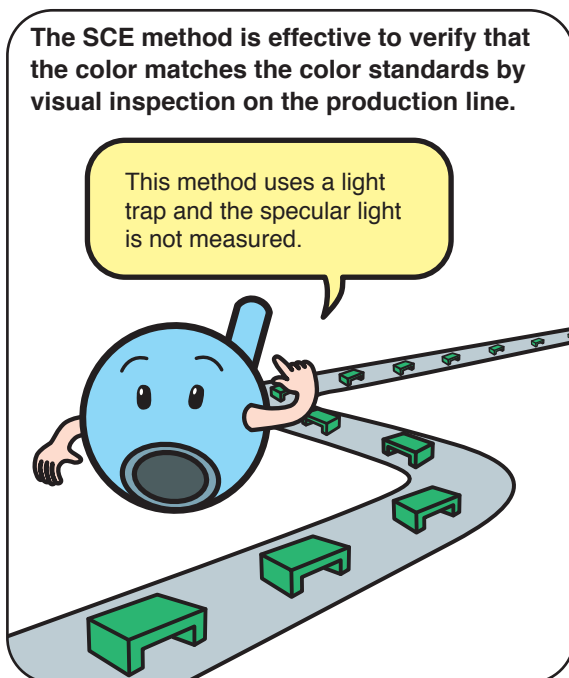

# Observing direction or illumination position differences

In general, viewing an object from a slightly different angle can make the object appear brighter or darker. This is due to the directional characteristics of the object, which are especially obvious with translucent or metallic colors. The angle from which the object is viewed, and also the angle from which it is illuminated, must be constant for accurate color communication.

## < Types of Optical Systems (geometries) >

A color looks different depending on the viewing conditions, such as the observation angle and illumination angle. When a color meter measures the color of an object, the conditions, including the angle at which a beam of light from a source strikes the object and the angle at which the light is received by a detector, are called the optical geometry, and are defined by CIE and JIS.

### Unidirectional Illumination System

This is a method which provides illumination from one direction (angle). With a geometry of  $45^\circ:n$  ( $45^\circ:0^\circ$ ), the specimen surface is illuminated from an angle of  $45 \pm 5$  degrees to the normal line and the light is received in the normal direction ( $0 \pm 5$  degree). With a geometry of  $n:45^\circ$  ( $0^\circ:45^\circ$ ), the specimen surface is illuminated from the normal line direction ( $0 \pm 5$  degree) and the light is received at the angle of  $45 \pm 5$  degrees to the normal line. For the  $45^\circ:n$  illuminating/viewing system, three types of illumination are available: Annular (Ring-shaped) illumination ( $45^\circ a:0^\circ$ ) with light sources positioned in a circle continuously; circumferential illumination ( $45^\circ c:0^\circ$ ) with light sources positioned in a circle at some intervals; and single-directional illumination ( $45^\circ x:0^\circ$ ).

### Diffused Illumination Integrating Sphere System

This system uses an integrating sphere for illuminating and viewing a specimen uniformly from all directions. (An integrating sphere is a spherical device with internal surfaces coated with a white material such as barium sulfate so the light is uniformly diffused). An instrument with  $d:n$  ( $de:8^\circ$ ,  $D:n$  ( $di:8^\circ$ ) optical geometry illuminates the specimen diffusely and detects the light at 8 degrees to the normal line ( $8 \pm 5$  degrees). An instrument with  $n:d$  ( $8^\circ:de$ ),  $n:D$  ( $8^\circ:di$ ) optical geometry illuminates the specimen at 8 degrees to the normal line ( $8 \pm 5$  degrees) and collects the light reflected in all directions. (Reflected light within  $\pm 5$  degrees from the specular angle can be included or excluded using the SCE/SCI function.)

Figure 21 : Illuminating/viewing systems

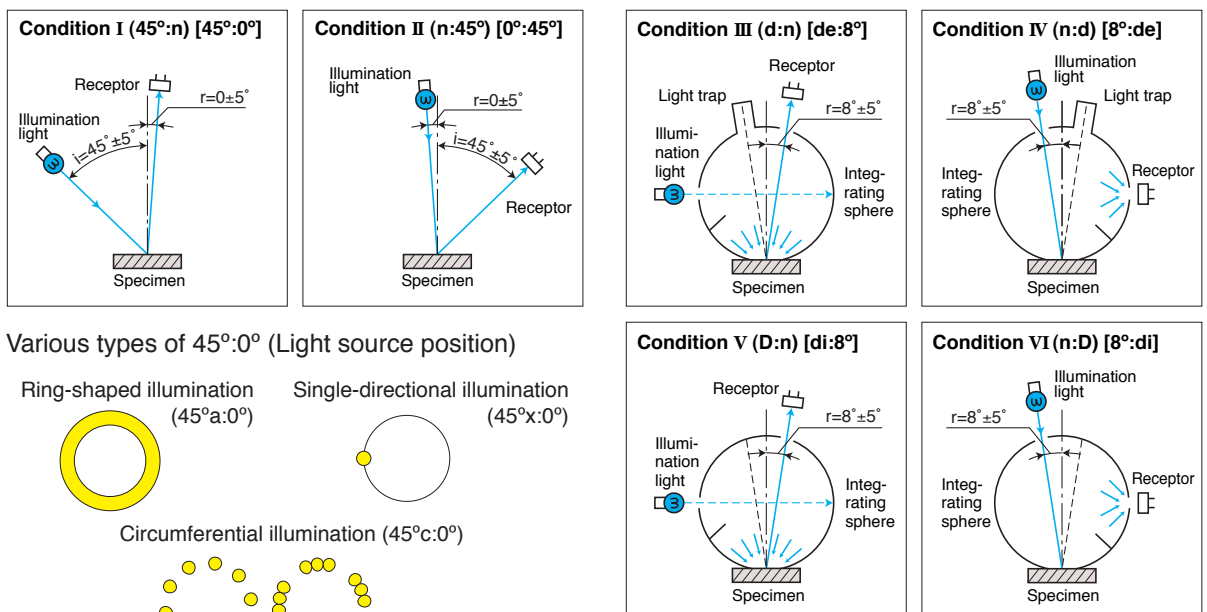

# Colors also look different due to optical illusions and individual differences.

## Size differences (optical illusion)

After looking at small sample pieces and selecting a wallpaper which looks good, people sometimes find that it looks too bright when it's actually hung on the wall. Colors covering a large area tend to appear brighter and more vivid than colors covering a smaller area. This is referred to as an area effect. Selecting objects which will have a large area based on color samples with a small area may result in mistakes.

## Observer differences (individual differences)

The sensitivity of each individuals' eyes is slightly different; even for people considered to have "normal" color vision, there may be some bias toward red or blue. Also, a person's eyesight generally changes with age. Because of these factors, colors will appear differently to different observers.

## Background differences (optical illusion)

If an apple is placed in front of a bright background, it will appear duller than when it is placed in front of a dark background. This is referred to as a contrast effect, and is undesirable for accurately judging color.

It's important to keep conditions constant when viewing colors.



# Spectrophotometers solve these problems easily and quickly.

Spectrophotometers offer a wide range of features and superior accuracy so that they can express colors numerically and show spectral reflectance graphs for colors. By using the included data for a variety of illumination conditions, spectrophotometers can solve various problems which could not be solved with tristimulus colorimeters, including color rendering properties (apparent color differences caused by the light source), metamerism, and surface condition differences.

## < Major features and functions of spectrophotometers >

Photo shows Konica Minolta Spectrophotometer CM-700d.



# Measuring Special Colors

## < Metallic Colors >

Many coatings, especially automotive applications, use a combination of metallic flake and colorant to achieve a colorful effect. In a metallic coating, light is reflected at different angles due to the orientation of the flakes of metal in the coating, although the flakes will generally be aligned in the same direction. Figure 22 illustrates how the specular reflectance and diffuse reflectance interact with a metallic coating. Because the color reflects from the metallic flake at a different angle than the diffuse reflectance, the appearance to the human eye will also differ. At the angle close to the specular reflection, highlight color (face), which is influenced by the metallic flake, is seen. At the angle, which is not influenced by metallic flake, shade color (flop) is seen. In general, when measuring metallic colors, it is more effective to measure and evaluate them with a spectrophotometer that measures color at multiple angles.

## < Fluorescent colors >

When you see a fluorescent color, it looks like it is glowing by itself although it is not actually a light source. When light is applied to a fluorescent material, the rays are absorbed and re-emitted as visible light in other regions of the spectrum, usually at longer wavelengths. Visible light is electromagnetic radiation between approximately 380nm and 780nm. For example, when 360nm radiation is absorbed and emitted at 460nm, the measurement value at 460nm may exceed 100%. Since more than the expected amount of light is visible, it appears to the human eye as if the material glows by itself. For measurement of non-fluorescent samples, the dispersive element (such as a diffraction grating) can be placed either between the source and the sample or between the sample and the receiver. However for the measurement of fluorescent samples to agree with the color as it appears to people, the dispersive element must be placed between the sample and the detector so that the sample is illuminated by the entire spectrum of the source. When the fluorescent color is measured by a spectrophotometer, the spectral power distribution of the light source, including the ultraviolet regions, must be controlled.

Figure 22

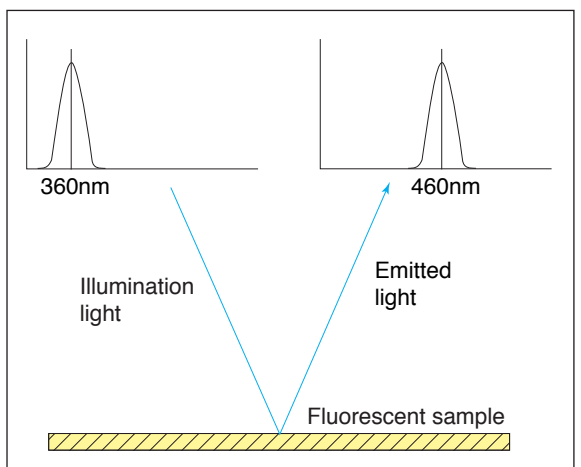
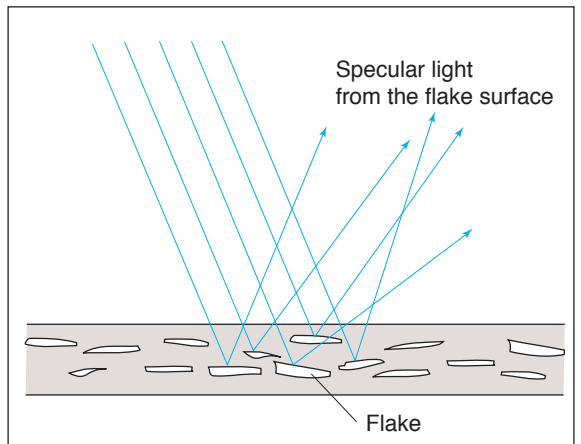
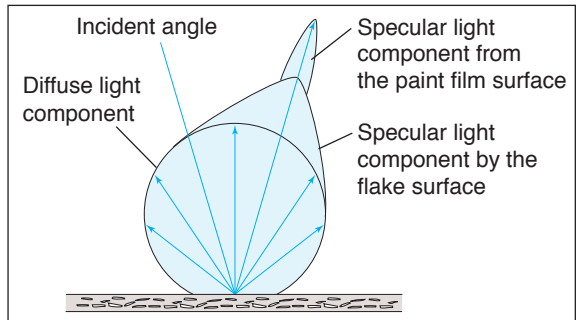

## Black Light and Fluorescent Material

Have you ever been in a room where appearances are striking because the white shirts, socks or patterns on the wall seem to be glowing and exceedingly bright while the room itself appears to be dark or illuminated in violet lighting?

A place like this is lit by a source called a black light. The black light is an illumination using wavelengths mostly outside the visible regions of the spectrum. It has been sold for illuminating fluorescent jigsaw puzzles or fluorescent minerals. In fact, this black light emits energy in the ultraviolet region. A fluorescent material that absorbs this energy and re-emits it as light in the visible region has been added to the objects. The materials appear to glow when illuminated by a black light.

An object appears white when it reflects all wavelengths in the visible regions at nearly 100 percent. However, if there is less reflectance at the blue wavelengths, the object appears yellowish.

In many cases, a fluorescent material (sometimes referred to as an optical brightener) is added.

This fluorescent material provides an increase in reflectance at the blue wavelengths to make the object seem white. As a result, a white shirt appears to glow when it is illuminated by a black light, and appears white in daylight. When white clothes are washed repeatedly, they become yellowish. This is not because they are stained by a yellow color, but because the fluorescent material is washed out and the original color of the cloth has re-appeared. It is a common practice to have the yellowish clothes returned to white by washing with a detergent that contains a fluorescent material.

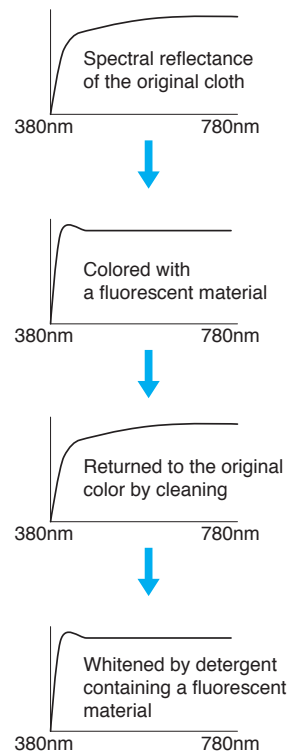

# Notes for Measurement (Subjects and Environment)

## Powder Measurement Objects

When measuring powder with a spectrophotometer, the measurement value varies depending on the density of the powder and the surface conditions. To avoid errors, special methods are required such as placing a fixed amount of powder into a container of a fixed shape and size and maintaining a fixed surface quality. If the size of the particles is large, use a spectrophotometer which has a large measurement area, so the measurement surface is averaged and a repeatable measurement value can be obtained.

## Measurement Objects Containing Patterns

When measuring objects that contain patterns or have textures, the measurement value varies according to the location if a small area. The largest possible measurement area should be used, or else the measurement should be taken several times in different locations, and then the average measurement value should be calculated.

## Transmissive Objects

The measurement of transmissive objects such as paper is affected by the light passing through the object. To measure the color of paper, for example, increase the thickness of the object (such as by stacking several sheets of paper) to prevent the light from being transmitted, or place an opaque white surface behind the object. To prevent the effect of the background, use a low-reflectance black surface as a background.

## Influence of Temperature Conditions

Sometimes when the temperature of the same object changes, the color will also change. This phenomenon is called thermochromism. To measure color accurately using the spectrophotometer, the measurement must be performed in a room with a fixed temperature after the measurement object has reached the room temperature.

Temperature characteristics when the BCRA color tile changes 10°C from the room temperature ( $\Delta E^*ab$ )  
(According to Konica Minolta test conditions.)

$\Delta E^*ab$

|           |      |
|-----------|------|
| White     | 0.01 |
| Pale grey | 0.02 |
| Mid grey  | 0.05 |
| Dif grey  | 0.05 |
| Deep grey | 0.05 |
| Deep pink | 0.60 |
| Orange    | 1.52 |
| Red       | 1.32 |
| Yellow    | 0.92 |
| Green     | 0.92 |
| Dif green | 0.91 |
| Cyan      | 0.46 |
| Deep blue | 0.17 |
| Black     | 0.02 |





## **New Color Difference Formula (CIE 2000)**

Color meters allow us to accurately communicate colors and color differences using numerical color data. At actual color management locations, however, sometimes the results of visual inspection do not match with the results obtained with color meters. Why? Is there any way to solve this problem? Yes, there is. It is the new color difference formula "CIE 2000" which will be explained in this section.

## Problems with CIE Lab ( $L^*a^*b^*$ color space)

CIE Lab ( $L^*a^*b^*$  color space) represents colors by using the coordinates in a uniform color space consisting of lightness variable  $L^*$  and chromaticity indices  $a^*$  and  $b^*$ . Although the calculation formula was defined based on the color vision of the human eye, some color differences are evaluated differently between the color difference  $\Delta E^*_{ab}$  and the human eye. This is because the color discrimination threshold of the human eye greatly differs from the range of color differences  $\Delta E^*_{ab}$  and  $\Delta a^*b^*$  defined by CIE Lab.

### Color discrimination threshold of the human eye

The human eye cannot differentiate some colors from others even if they are different. The area of such colors on the chromaticity diagram is called the color discrimination threshold of the human eye.

The figure on the right is part of the  $a^*b^*$  chromaticity diagram representing the CIE Lab color space. The white ellipses on the diagram represent the color discrimination thresholds of the human eye concerning saturation and hue. In other words, the human eye cannot differentiate the colors within the same ellipse.

A close look at these white ellipses shows the following four characteristics of the color differentiation ability of the human eye on the chromaticity diagram of CIE Lab ( $L^*a^*b^*$  color space).

- 1) The sensitivity to color differences is low for the colors with high saturation. Consequently, such colors are difficult to differentiate. (Saturation dependency is high.)

The shape of the ellipses becomes close to a circle for colors with low saturation, and it becomes longer in the direction of saturation and narrower in the direction of hue for colors with high saturation. This means that the human eye cannot differentiate colors with high saturation although their color difference is relatively great.

The human eye cannot differentiate the colors within this ellipse.

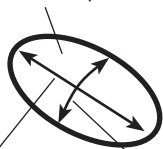

Long in saturation direction  
(Colors are difficult to differentiate.)

Narrow in hue direction  
(Colors are easier to differentiate.)

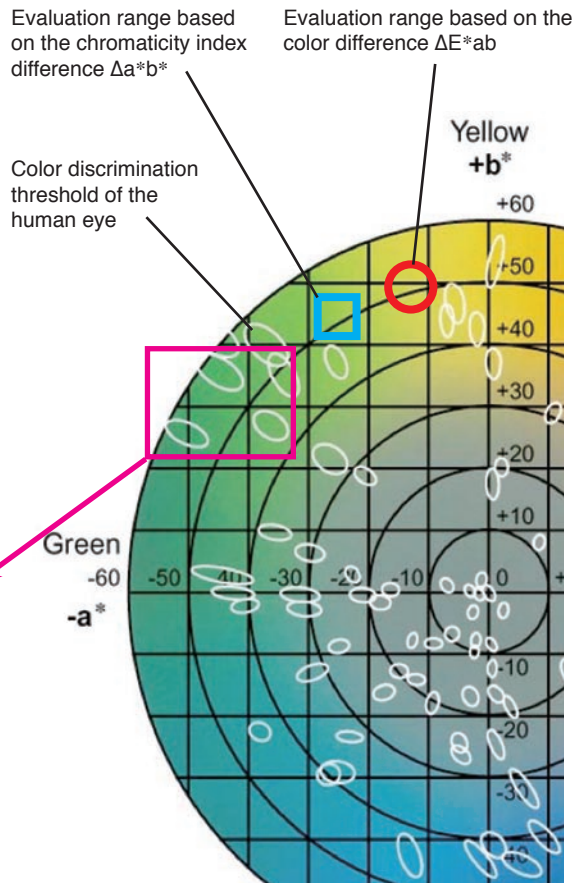

Note: The figures showing white ellipses representing the color discrimination thresholds of the human eye used on pages 50 and 51 are based on Figure 1 excerpted from the paper titled "The Development of the CIE 2000 Colour-Difference Formula: CIEDE2000" written by M.R. Luo, G. Cui, and B. Rigg, which appeared in COLOR Research and Application, No. 5 (Volume 26), page 341 published in October, 2001, with the cooperation and approval of the journal and authors. Figure 1 on page 341 of the journal is copyrighted by John Wiley & Sons, Inc.

2) The sensitivity to the color differences in the direction of hue varies depending on the hue. Look at white ellipses A and B in the diagram. A is located around the hue angle of 120 degrees (yellowish green), and B is located around the hue angle of 180 degrees (green). Although their saturation is similar, A is wider in the direction of hue, and B is narrower. This means that the sensitivity to the color differences regarding hue is higher in B than in A.

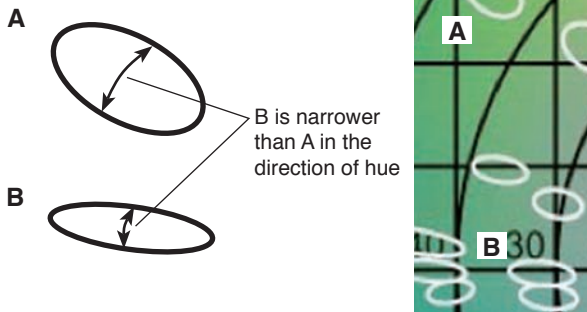

3) The sensitivity to the color difference in the direction of lightness varies depending on the lightness. Unfortunately, the lightness cannot be seen in the figure because it is represented by a normal line perpendicular to the diagram. It is said that the sensitivity becomes highest around the lightness of 50, and decreases for both higher and lower lightness.

4) For blue colors, the direction of the color discrimination threshold changes. The figure shows that the major axes of the white ellipses for blue colors do not match with the direction of saturation spreading from the center. It is this mismatch that causes differences in the color difference evaluation between color meters and the human eye.

The color difference  $\Delta E^*_{ab}$  generally used for the color difference evaluation with CIE Lab ( $L^*a^*b^*$  color space) is represented by a perfect circle for every saturation and hue as shown by  $\bigcirc$  in the figure on the right. The chromaticity index difference  $\Delta a^*b^*$ , another commonly-used evaluation method, is represented with a square as shown by  $\square$  in the figure. Both shapes differ considerably from the shape of the color discrimination threshold of the human eye (white ellipse). The differences in these shapes manifest themselves as the differences between the calculation result by color meters and the evaluation by the human eye.

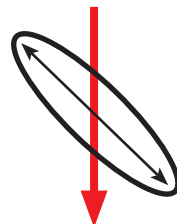
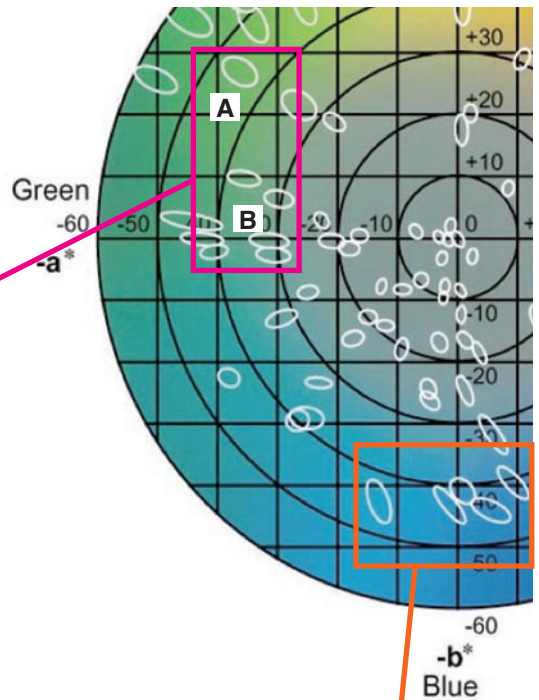

Direction of saturation



The major axis of the white ellipse representing the color discrimination threshold of the human eye is not in the direction of saturation.

Evaluation range based on the chromaticity index difference  $\Delta a^*b^*$

Evaluation range based on the color difference  $\Delta E^*_{ab}$

Color discrimination threshold of the human eye

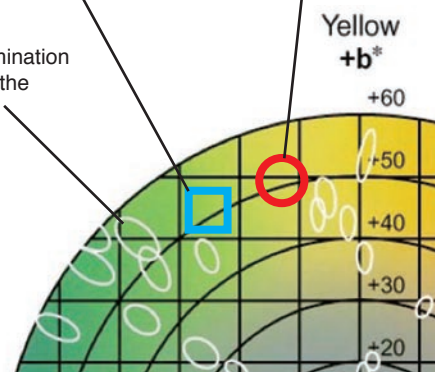

## Features of "CIE 2000" color difference formula

The CIE 2000 color difference formula was developed to solve the problem of the differences in the evaluation between color meters and the human eye caused by the difference in the shape and size of the color discrimination threshold of the human eye.

The CIE 2000 color difference formula is not an attempt to build a color space in which the widths of the color discrimination thresholds of the human eye are uniform. Instead, it defines a calculation so that the color difference calculated by color meters becomes close to the color discrimination threshold of the human eye on the solid color space of CIE Lab ( $L^*a^*b^*$  color space). Specifically, weight is assigned to the lightness difference  $\Delta L^*$ , saturation difference  $\Delta C^*$ , and hue difference  $\Delta H^*$  by using weighting coefficients  $S_L$ ,  $S_C$ , and  $S_h$  respectively. These weighting coefficients  $S_L$ ,  $S_C$ , and  $S_h$  include the effects of lightness  $L^*$ , saturation  $C^*$ , and hue angle  $h$ . Consequently, the calculation incorporates the characteristics of the color discrimination threshold of the human eye on the color space of CIE Lab ( $L^*a^*b^*$  color system): 1) Saturation dependency, 2) Hue dependency, and 3) Lightness dependency.

*\* For the specific calculation formula, refer to the next chapter "COLOR TERMS".*

With the CIE Lab ( $L^*a^*b^*$  color space) color difference formula, the color difference evaluation ranges represented by color difference  $\Delta E^*_{ab}$  and chromaticity index difference  $\Delta a^*b^*$  were a perfect circle or a square in the  $L^*a^*b^*$  solid color space. With CIE 2000, color difference  $\Delta E_{00}$  is represented with an ellipse having the major axis in the direction of saturation, which is similar to the shape of the color discrimination threshold of the human eye. In the region with lower saturation, the weighing coefficients  $S_L$ ,  $S_C$ , and  $S_h$  approach 1 respectively, making the ellipse more circular.

In the region with higher saturation, the weighing coefficient  $S_C$  becomes greater compared with other coefficients  $S_L$  and  $S_h$ , so that the ellipse becomes longer in the direction of saturation (lower sensitivity to saturation differences).

With the CIE 2000 color difference formula, the effect on the hue angle is also considered. As a result, the formula can cope with another characteristic of the color discrimination threshold of the human eye on the color space of CIE Lab ( $L^*a^*b^*$  color space): 4) Change in the direction of the color discrimination threshold around the hue angle of 270 degrees (blue) (deviation from the direction of saturation).

The calculation formula also includes constants  $k_L$ ,  $k_C$ , and  $k_h$ , called parametric coefficients. Users can specify their values as desired to obtain flexibility for conducting color management according to various objects.

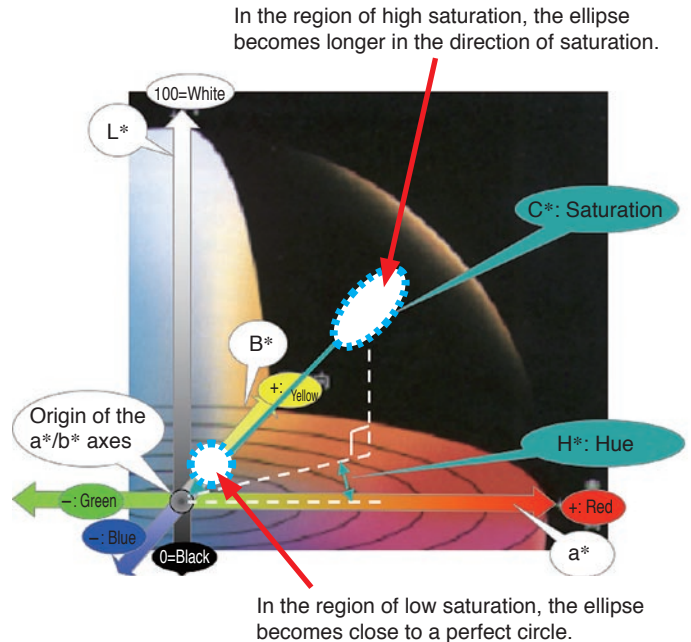

## **COLOR TERMS**

This section includes further details about terms, standards, and color spaces discussed in this booklet. Since the explanation is based on CIE (Commission Internationale de l'Eclairage), some unfamiliar terms and complicated calculations are included. This section is intended as a reference.

## 2° Standard Observer and 10° Supplementary Standard Observer

The color response of the eye changes according to the angle of view (object size). The CIE originally defined the standard observer in 1931 using a 2° field of view, hence the name 2° Standard Observer. In 1964, the CIE defined an additional standard observer, this time based upon a 10° field of view; this is referred to as the 10° Supplementary Standard Observer. To give an idea of what a 2° field of view is like compared to a 10° field of view, at a viewing distance of 50cm a 2° field of view would be a  $\phi 1.7\text{cm}$  circle while a 10° field of view at the same distance would be a  $\phi 8.8\text{cm}$  circle. The 2° Standard Observer should be used for viewing angles of 1° to 4°; the 10° Supplementary Standard Observer should be used for viewing angles of more than 4°.

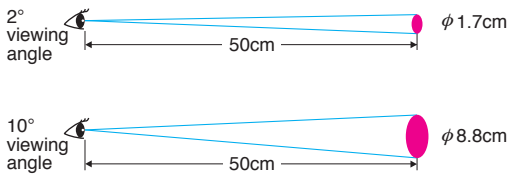

## Color-Matching Functions

The color-matching functions are the tristimulus values of the equal-energy spectrum as a function of wavelength. These functions are intended to correspond to the response of the human eye. Separate sets of three color-matching functions are specified for the 2° Standard Observer and 10° Supplementary Standard Observer.

Color-matching functions

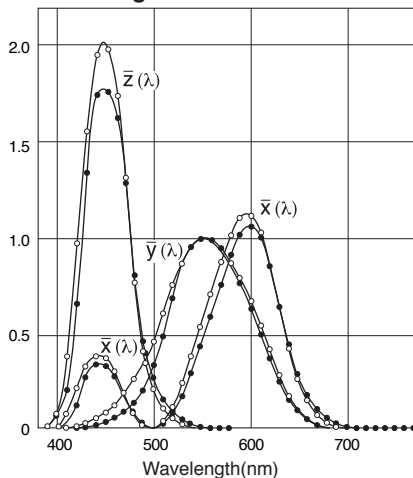

- 2° Standard Observer
- 10° Supplementary Standard Observer

## XYZ Tristimulus Values (CIE 1931)

Tristimulus values determined based on the color-matching functions  $\bar{x}(\lambda)$ ,  $\bar{y}(\lambda)$ , and  $\bar{z}(\lambda)$  defined in 1931 by CIE; also referred to as 2° XYZ tristimulus values. They are suitable for a viewing angle of 4° or less and are defined for reflecting objects by the following formulas:

$$X = K \int_{380}^{780} S(\lambda) \bar{x}(\lambda) R(\lambda) d\lambda$$

$$Y = K \int_{380}^{780} S(\lambda) \bar{y}(\lambda) R(\lambda) d\lambda$$

$$Z = K \int_{380}^{780} S(\lambda) \bar{z}(\lambda) R(\lambda) d\lambda$$

$$K = \frac{100}{\int_{380}^{780} S(\lambda) \bar{y}(\lambda) d\lambda}$$

where

$S(\lambda)$ : Relative spectral power distribution of the illuminant

$\bar{x}(\lambda)$ ,  $\bar{y}(\lambda)$ ,  $\bar{z}(\lambda)$ : Color-matching functions for CIE 2° Standard Observer (1931)

$R(\lambda)$ : Spectral reflectance of specimen

## X<sub>10</sub> Y<sub>10</sub> Z<sub>10</sub> Tristimulus Values (CIE 1964)

Tristimulus values determined based on the colormatching functions  $\bar{x}_{10}(\lambda)$ ,  $\bar{y}_{10}(\lambda)$ , and  $\bar{z}_{10}(\lambda)$  defined in 1964 by CIE; also referred to as 10° XYZ tristimulus values. They are suitable for a viewing angle of more than 4° and are defined for reflecting objects by the following formulas:

$$X_{10} = K \int_{380}^{780} S(\lambda) \bar{x}_{10}(\lambda) R(\lambda) d\lambda$$

$$Y_{10} = K \int_{380}^{780} S(\lambda) \bar{y}_{10}(\lambda) R(\lambda) d\lambda$$

$$Z_{10} = K \int_{380}^{780} S(\lambda) \bar{z}_{10}(\lambda) R(\lambda) d\lambda$$

$$K = \frac{100}{\int_{380}^{780} S(\lambda) \bar{y}_{10}(\lambda) d\lambda}$$

where

$S(\lambda)$ : Relative spectral power distribution of the illuminant

$\bar{x}_{10}(\lambda)$ ,  $\bar{y}_{10}(\lambda)$ ,  $\bar{z}_{10}(\lambda)$ : Color-matching functions for CIE 10° Supplementary Standard Observer (1964)

$R(\lambda)$ : Spectral reflectance of specimen

## xyz Chromaticity Coordinates

The xyz chromaticity coordinates are calculated from the XYZ tristimulus values according to the following formulas:

$$x = \frac{X}{X+Y+Z}$$

$$y = \frac{Y}{X+Y+Z}$$

$$z = \frac{Z}{X+Y+Z} = 1 - x - y$$

If the above formulas are used with the X10 Y10 Z10 tristimulus values, the chromaticity coordinates would be x10 y10 z10.

## xy and x10 y10 Chromaticity Diagram

Two-dimension diagram on which the xy or x10 y10 chromaticity coordinates can be plotted.

### xy and x10y10 chromaticity diagram

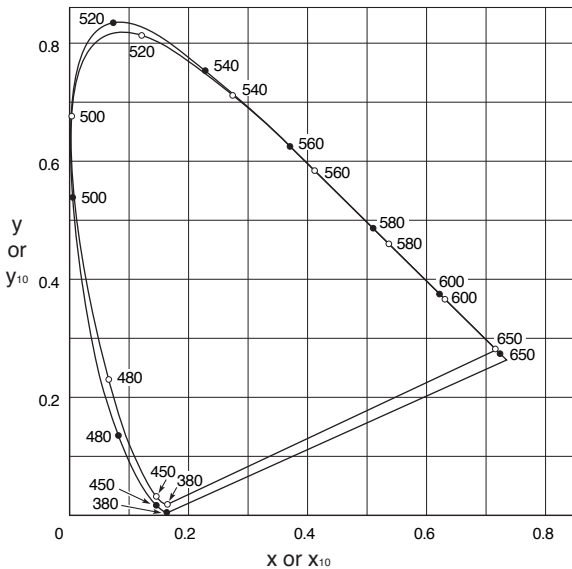

- For 2° Standard Observer (CIE 1931)
- For 10° Supplementary Standard Observer (CIE 1964)

## L\*a\*b\* Color Space

The L\*a\*b\* color space (also referred to as the CIELAB space) is one of the uniform color spaces defined by the CIE in 1976. The values of L\*, a\*, and b\* are calculated according to the formulas below:

Lightness variable L\*:

$$L^* = 116 \left( \frac{Y}{Y_n} \right)^{1/3} - 16$$

Chromaticity coordinates a\* and b\*:

$$a^* = 500 \left[ \left( \frac{X}{X_n} \right)^{1/3} - \left( \frac{Y}{Y_n} \right)^{1/3} \right]$$

$$b^* = 200 \left[ \left( \frac{Y}{Y_n} \right)^{1/3} - \left( \frac{Z}{Z_n} \right)^{1/3} \right]$$

where

X, Y, Z: Tristimulus values XYZ (for 2° Standard Observer) or X10Y10Z10 (for 10° Supplementary Standard Observer) of the specimen

Xn, Yn, Zn: Tristimulus values XYZ (for 2° Standard Observer) or X10Y10Z10 (for 10° Supplementary Standard Observer) of a perfect reflecting diffuser.

If X/Xn, Y/Yn, or Z/Zn is less than (24/116)<sup>3</sup>, the above equations are changed as described below:

$$\left( \frac{X}{X_n} \right)^{1/3} \text{ is replaced by } \frac{841}{108} \left( \frac{X}{X_n} \right) + \frac{16}{116}$$

$$\left( \frac{Y}{Y_n} \right)^{1/3} \text{ is replaced by } \frac{841}{108} \left( \frac{Y}{Y_n} \right) + \frac{16}{116}$$

$$\left( \frac{Z}{Z_n} \right)^{1/3} \text{ is replaced by } \frac{841}{108} \left( \frac{Z}{Z_n} \right) + \frac{16}{116}$$

Color difference  $\Delta E^*_{ab}$  in the L\*a\*b\* color space, which indicates the degree of color difference but not the direction, is defined by the following equation:

$$\Delta E^*_{ab} = \sqrt{(\Delta L^*)^2 + (\Delta a^*)^2 + (\Delta b^*)^2}$$

where

$\Delta L^*$ ,  $\Delta a^*$ ,  $\Delta b^*$ : Difference in L\*, a\*, and b\* values between the specimen color and the target color.

## Uniform Color Space

A color space in which equal distances on the coordinate diagram correspond to equal perceived color differences.

## L\*C\*h Color Space

The L\*C\*h color space uses the same diagram as the L\*a\*b\* color space, but uses cylindrical coordinates. Lightness L\* is the same as L\* in the L\*a\*b\* color space; Metric Chroma C\* and Metric Hue-Angle h are defined by the following formulas:

$$\text{Metric chroma: } C^* = \sqrt{(a^*)^2 + (b^*)^2}$$

$$\text{Metric Hue-Angle: } h = \tan^{-1} \left( \frac{b^*}{a^*} \right) \text{ [degrees]}$$

where

a\*, b\*: Chromaticity coordinates in the L\*a\*b\* color space

For difference measurements, Metric Hue-Angle difference is not calculated; instead, Metric Hue-Difference  $\Delta H^*$  is calculated according to the following formula:

$$\begin{aligned} \Delta H^* &= \sqrt{(\Delta E^*_{ab})^2 - (\Delta L^*)^2 - (\Delta C^*)^2} \\ &= \sqrt{(\Delta a^*)^2 + (\Delta b^*)^2 - (\Delta C^*)^2} \end{aligned}$$

The Metric Hue-Difference is positive if the Metric Hue-Angle h of the specimen is greater than that of the target and negative if the Metric Hue-Angle of the specimen is less than that of the target.

## CIE 2000 Color difference formula

As described on page 49 of this booklet, this is the newest color difference formula intended to correct the differences between the measurement result and visual evaluation, which was the weak point in the L\*a\*b\* color space. The calculation is based on the lightness difference  $\Delta L^*$ , saturation difference  $\Delta C^*$ , and hue difference  $\Delta H^*$ , with correction using weighing coefficients (SL, SC, and SH) and constants called parametric coefficients (kL, kC, and kH), as shown below.

$$\Delta E_{00} = \sqrt{\left( \frac{\Delta L^*}{k_L \cdot S_L} \right)^2 + \left( \frac{\Delta C^*}{k_C \cdot S_C} \right)^2 + \left( \frac{\Delta H^*}{k_H \cdot S_H} \right)^2 + \left( R_T \frac{\Delta C^*}{k_C \cdot S_C} \right) \left( \frac{\Delta H^*}{k_H \cdot S_H} \right)}$$

where

$$L' = L^* \quad b' = b^* \quad a' = a^*(1+G)$$

$$C' = \sqrt{(a')^2 + (b')^2} \quad h' = \tan^{-1} \left( \frac{b'}{a'} \right)$$

$$G = 0.5 \left( 1 - \sqrt{\frac{\bar{C}^*_{ab}{}^7}{\bar{C}^*_{ab}{}^7 + 25^7}} \right) \quad S_L = 1 + \frac{0.015 (\bar{L}^* - 50)^2}{\sqrt{20 + (\bar{L}^* - 50)^2}}$$

$$S_C = 1 + 0.045 \bar{C}'$$

$$S_H = 1 + 0.015 \bar{C}' T$$

$$T = 1 - 0.17 \cos(\bar{h}' - 30) + 0.24 \cos(2\bar{h}') + 0.32 \cos(3\bar{h}' + 6) - 0.20 \cos(4\bar{h}' - 63)$$

$$R_T = -\sin(2\Delta \theta) R_C$$

$$\Delta \theta = 30 \exp \left( - \left( \frac{\bar{h}' - 275}{25} \right)^2 \right)$$

$$R_C = 2 \sqrt{\frac{\bar{C}'^7}{\bar{C}'^7 + 25^7}}$$

## Munsell Color System

The Munsell color system consists of a series of color charts which are intended to be used for visual comparison with the specimen. Colors are defined in terms of the Munsell Hue (H; indicates hue), Munsell Value (V; indicates lightness), and Munsell Chroma (C; indicates saturation) and written as H V/C. For example, for the color with H=5.0R, V=4.0, and C=14.0, the Munsell notation would be: 5.0R 4.0/14.0

### The Munsell hue circle

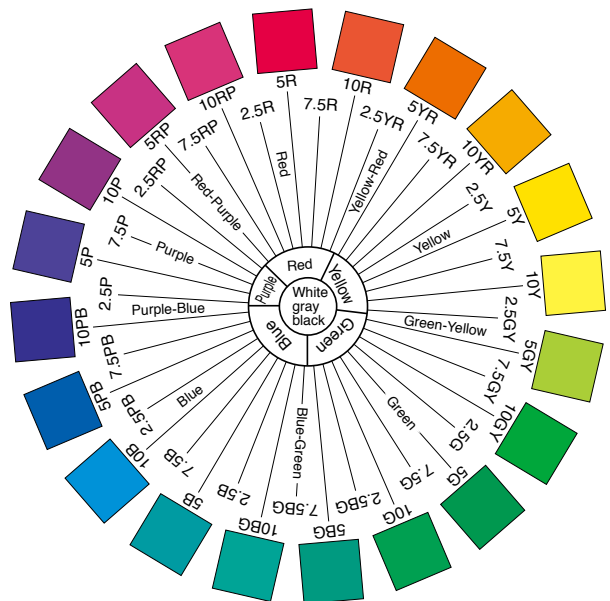



**The Munsell color chip  
(The brightness and chroma of 2-5R)**

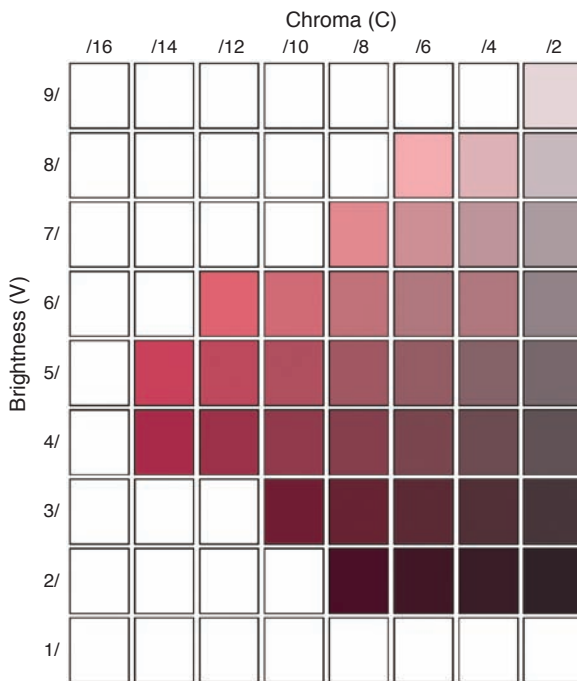

**L\*u\*v\* Color Space**

The L\*u\*v\* color space (also referred to as the CIELUV space) is one of the uniform color spaces defined by the CIE in 1976. The values of L\*, u\*, and v\* are calculated according to the formulas below:

$$L^* = 116 \left( \frac{Y}{Y_0} \right)^{1/3} - 16 \quad \text{when } \frac{Y}{Y_0} > \left( \frac{24}{116} \right)^3$$

$$u^* = 13L^*(u' - u'_0)$$

$$v^* = 13L^*(v' - v'_0)$$

where

Y: Tristimulus value Y (tristimulus value Y<sub>10</sub> can also be used.)

u', v': Chromaticity coordinates from the CIE 1976 UCS diagram

Y<sub>0</sub>, u'<sub>0</sub>, v'<sub>0</sub>: Tristimulus value Y (or Y<sub>10</sub>) and chromaticity coordinates u', v' of the perfect reflecting diffuser.

Color difference ΔE\*<sub>uv</sub> in the L\*u\*v\* color space, which indicates the degree of color difference but not the direction, is defined by the following equation:

$$\Delta E^*_{uv} = \sqrt{(\Delta L^*)^2 + (\Delta u^*)^2 + (\Delta v^*)^2}$$

where

ΔL\*, Δu\*, Δv\*: Difference in L\*, u\*, and v\* values between the specimen color and the target color

**CIE 1976 UCS Diagram**

The CIE 1976 UCS Diagram was defined by the CIE in 1976. It is intended to provide a perceptually more uniform color spacing for colors at approximately the same luminance. The values of u' and v' can be calculated from the tristimulus values XYZ (or X<sub>10</sub>Y<sub>10</sub>Z<sub>10</sub>) or from the chromaticity coordinates xy according to the following formulas:

$$u' = \frac{4X}{X+15Y+3Z} = \frac{4x}{-2x+12y+3}$$

$$v' = \frac{9Y}{X+15Y+3Z} = \frac{9y}{-2x+12y+3}$$

where

X, Y, Z: Tristimulus values (If tristimulus values X<sub>10</sub>Y<sub>10</sub>Z<sub>10</sub> are used, the results will be u'<sub>10</sub> and v'<sub>10</sub>.)

x, y: Chromaticity coordinates (If chromaticity coordinates x<sub>10</sub>y<sub>10</sub> are used, the results will be u'<sub>10</sub> and v'<sub>10</sub>.)

**CIE 1976 UCS Diagram (for 2° Standard Observer)**

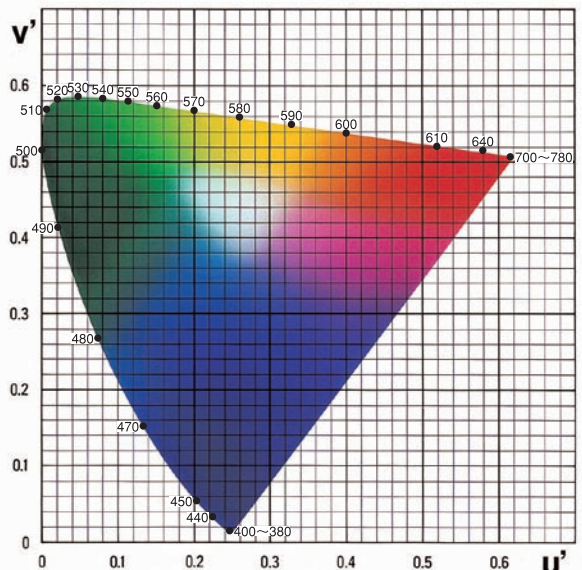

# Differences Between Object Color and Source Color

Determining the color of an object was described previously. However, there is a difference when a color is created independently such as by a light bulb. This is called source color. The following is a simple explanation of the differences between object and source color.

## Definition Differences

There are three basic factors involved when a human observes the color of an object. They are illumination, the object, and the perception of the observer. However, when a source is observed, there are only two factors: the spectral distribution of the light source and the perception of the observer. The formulas for these concepts are illustrated below.

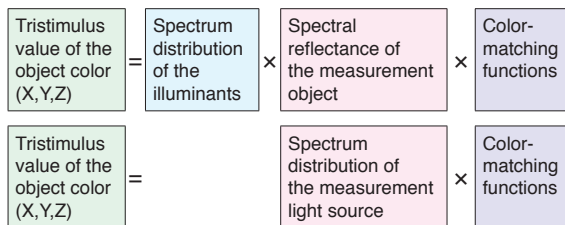

For object color, it is necessary to determine and evaluate the spectral distribution of the illuminants. This is because the color appears differently when the light source varies. The illuminants are not required when the light source color is measured because the color of the light source itself must be determined.

## Differences in the Geometrical Conditions of Illumination and Optical Reception

The optical geometry must be considered because the object color may vary under different conditions. Six types of conditions defined by CIE and JIS are described on page 42. These conditions are not used to determine the light source color. However, there are certain angular characteristics in which hue varies depending on the type of the light source and the viewing angle, such as with LCDs. In these cases, the observation angle must be fixed at a set value.

## Object Color Definition Formulas

$$X = K \int_{380}^{780} S(\lambda) \bar{x}(\lambda) R(\lambda) d\lambda \quad Y = K \int_{380}^{780} S(\lambda) \bar{y}(\lambda) R(\lambda) d\lambda$$

$$Z = K \int_{380}^{780} S(\lambda) \bar{z}(\lambda) R(\lambda) d\lambda \quad K = \frac{100}{\int_{380}^{780} S(\lambda) \bar{y}(\lambda) d\lambda}$$

Here:  $S(\lambda)$ : Relative spectral power distribution of the illuminant  $\bar{x}(\lambda), \bar{y}(\lambda), \bar{z}(\lambda)$ ,: Color matching function in the XYZ color space  
 $R(\lambda)$ : spectral reflectance of the object

## Light Source Color Definition Formulas

$$X = K \int_{380}^{780} S(\lambda) \bar{x}(\lambda) d\lambda \quad Y = K \int_{380}^{780} S(\lambda) \bar{y}(\lambda) d\lambda$$

$$Z = K \int_{380}^{780} S(\lambda) \bar{z}(\lambda) d\lambda$$

Here:  $S(\lambda)$ : Relative spectral power distribution of the radiant quantity from the light source  $\bar{x}(\lambda), \bar{y}(\lambda), \bar{z}(\lambda)$ ,: Color matching function in the XYZ color space

K: Normalizing color factor  
 (The tristimulus value Y is set to conform to the measurement light quantity.)

Use the following equation to determine the absolute value of the measurement light quantity when  $S(\lambda)$  is the absolute value of the spectrum radiation density for the XYZ color space.  
 $K=683 \text{ lm/w}$

## Color Space Representation

There are several common methods to describe light source color numerically. They include the xy coordinates, the CIE 1960 UCS color intensity (u, v), the CIE 1976 UCS color intensity (u\*, v\*), and (color temperature)\*

\* Refer to the page on the right for information about light source color temperature. The  $L^*u^*v^*$  color space (CIE LUV) is also used. However, the standard light must be determined when used in the light source color because the  $L^*u^*v^*$  color space is based on the color of a uniformly diffusing surface as an origin point.

# Color Temperature

As the temperature of an object increases, the emitted thermal radiation also increases. At the same time, the color changes from red through orange to white. A black body is an ideal object that absorbs all energy and emits it as radiant energy in such a manner so that its temperature is directly related to the color of the radiant energy given off. The absolute temperature of the black body is referred to as the color temperature. These colors would lie in the ideal black body locus, as indicated in the xy chromaticity chart shown in Figure 23.

Correlated color temperature is used to apply the general idea of color temperature to those colors that are close to, but not exactly, on the blackbody locus. The correlated color temperature is calculated by determining the isothermure line on which the color of the light source is positioned. Isothermure lines are straight lines for which all colors on the line appear visually equal; the correlated color temperature of any color on the isothermure line is equal to the color temperature at the point where the isothermure line intersects the blackbody locus.

The blackbody locus, the isothermure lines and lines that indicate equal values of  $\Delta uv$  from the blackbody locus are illustrated in Figure 24. For example, a light source which has a color difference of 0.01 in the green direction ( $\Delta uv$ ) from a black body which has a color temperature of 7000K is indicated as having a correlated color temperature of 7000K+0.01 ( $\Delta uv$  unit).

### Notes

"K" is an abbreviation for Kelvin. Kelvin is the absolute temperature scale.

Figure 23 xy chromaticity of the black body locus

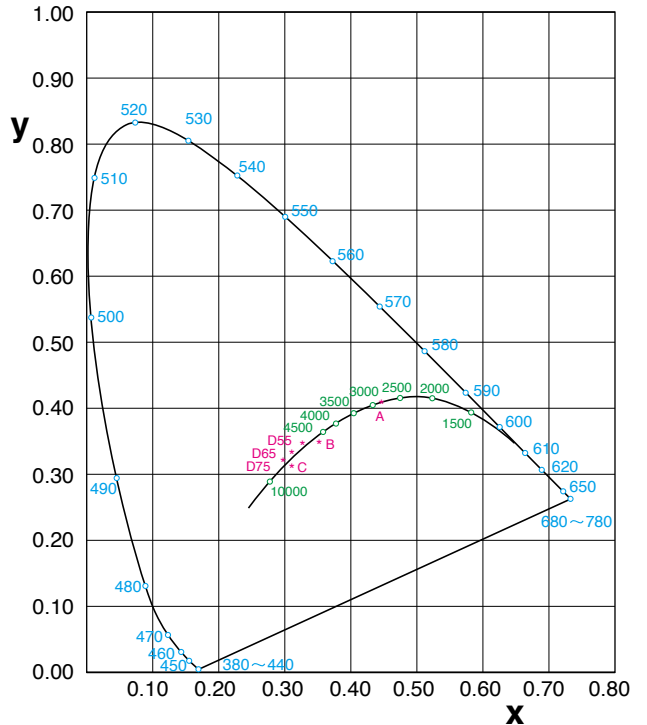
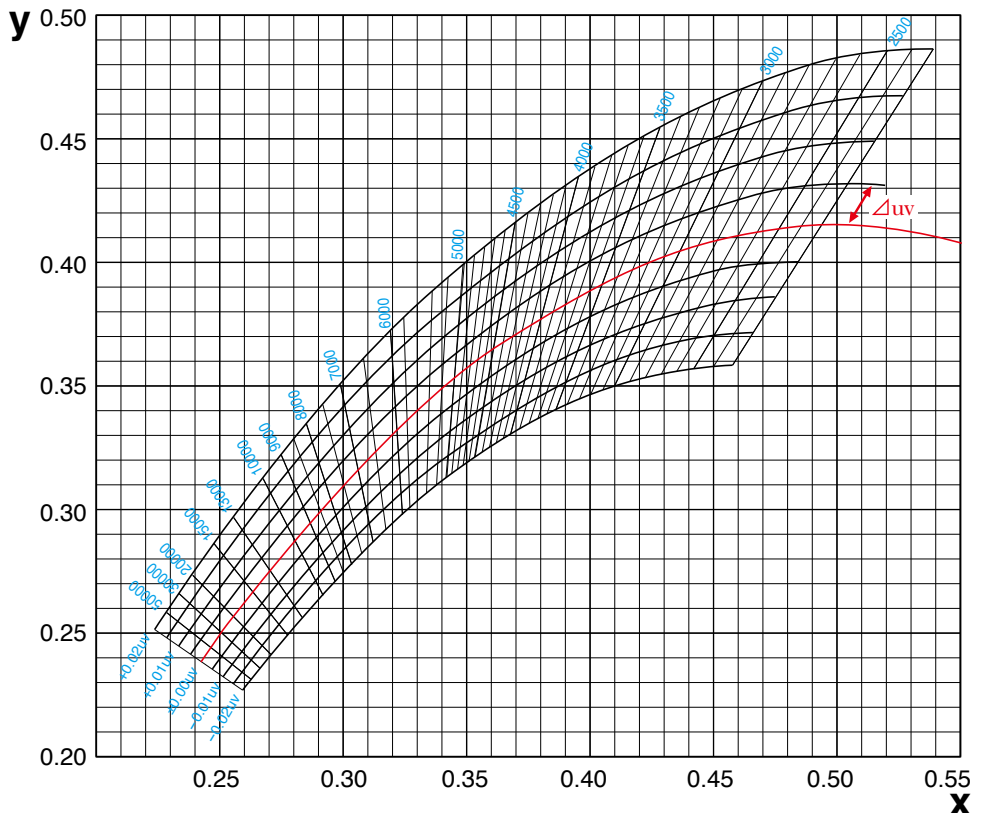

Figure 24 xy chromaticity chart indicating the black body locus, isothermure lines and equal  $\Delta uv$  lines.



# Memo

# Memo



**KONICA MINOLTA**